

REVISIONS			
REV	DATE	DESCRIPTION	REV. BY
00	6/24/2016	FIRST RELEASE	HM Z

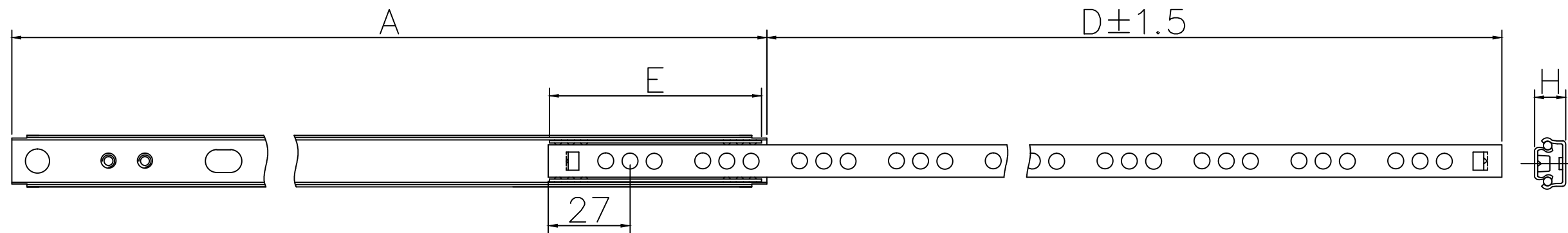

SLIDE DETAIL	ISL A	EXT D
17x178x178	178	129
17x182x182	182	133
17x214x214	214	140
17x246x246	246	172
17x278x278	278	204
17x310x310	310	212
17x342x342	342	244
17x350x350	350	252
17x374x374	374	276
17x406x406	406	308
17x438x438	438	318
17x450x450	450	330
17x470x470	470	350
17x502x502	502	382

MATERIAL THICKNESS	SLIDE HEIGHT
1.0	9.9±0.1
0.9	9.8±0.1
0.8	9.8±0.2

NOTES (UNLESS OTHERWISE SPECIFIED):

- PART OUTER SURFACE SHOULD BE CLEAN AND FREE FROM FOREIGN MATERIALS.
- MATERIAL: WORK-HARDENED COLD-ROLLED STEEL.
- LUBRICANT: HIGH AND LOW TEMP GREASE.
- FINISHING: PRE-PLATED STEEL TO BE COMPLIANT WITH ROHS, SALT SPRAY TEST REQUIRES MINIMUM 24 HOURS.
- LOADING RATE PER PAIR SLIDES: 10KGS
- LIFE CYCLE: 50K
- DIMENSIONS AND TOLERANCE FOLLOW ISO2768-M

Customer part no.		Dimensions within brackets are reference dimensions.	
Thomas Regout Int. B.V. reserves the right to alter non-customer specific specifications without notice.			
Date	Jun 24, 2016	Gen.Tol.Dim.	± 0.5
Approver		Gen.Tol.Angle	± 0.5
Date		Gen.Roughness	Ra
		Units	mm/deg.
Description		Third angle projection	Material PRE-PLATED STEEL (SECC)
17 SERIES BALL BEARING SLIDE			Finish N/A
Format	A3		Draw type Fabrication
Item No.		Scale 1 : 1	Type
136-17AXX		Model No.	
Revision		00	
© THOMAS REGOUT INTERNATIONAL BV, Industrieweg 40, 6219 NR, Maastricht, The Netherlands, +31 (0)43 351 66 66 All rights are reserved.			