

FRONT

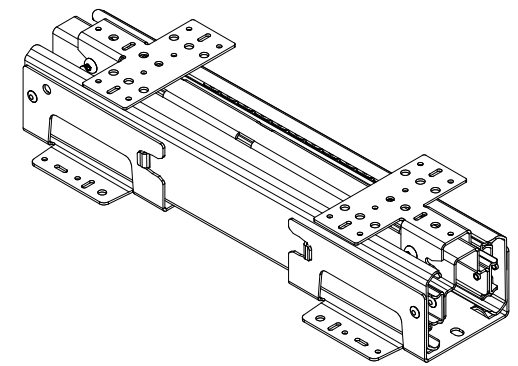
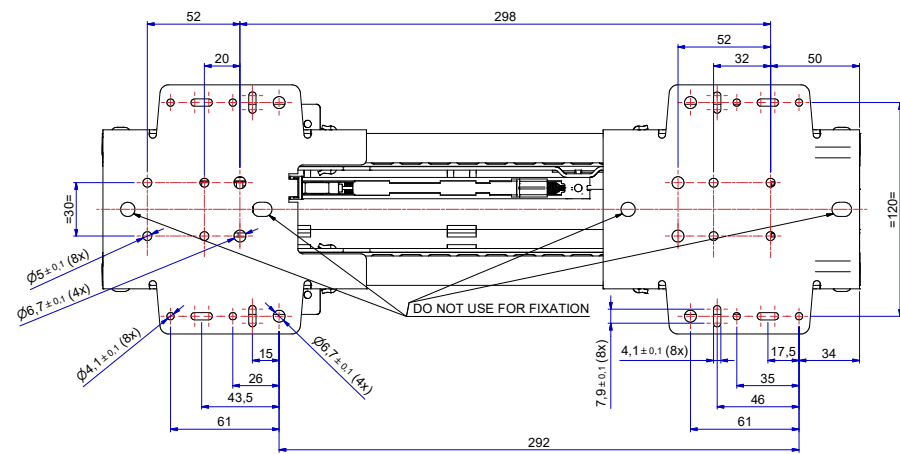
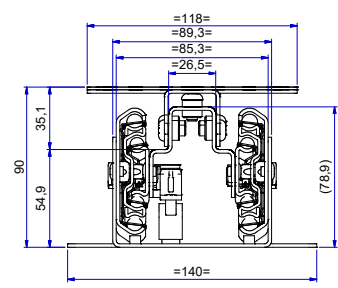
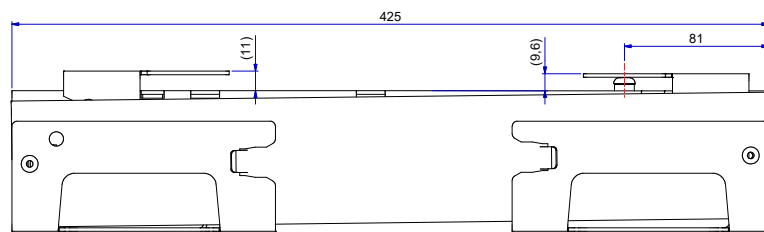

Designer	Ronald Cornelissen	Gen.Tol.Dim.	$\pm 0,5$	Third angle projection	Material
Date	24-8-2017	Gen.Tol.Angle	$\pm 1$	Treatment	
Approver		Gen.Roughness	Ra	Draw type	Fabrication
Date		Units	mm/deg.	Scale	1 : 1,5 Type
Description				Released for Production	
LARDER UNIT 425 TITAN				Item No.	150-A67
Form	A1	THOMAS REGOUT INTERNATIONAL B.V.		Revision	00
© THOMAS REGOUT INTERNATIONAL B.V. Industrieweg 40, 6219 NR, Maastricht, The Netherlands, +31 (0)43 351 66 66 All rights are reserved.					