

1 2 3 4 5 6 7 8 9 10 11 12 13 14 15 16 17 18 19 20

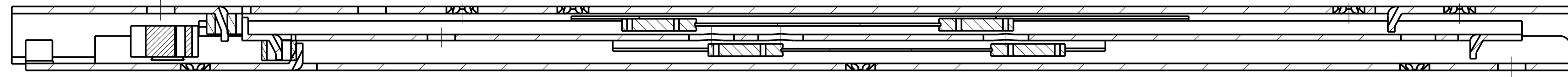

SECTION A-A

T 1-2 = 216.0
T 2-3 = 234.0

EXTENSION 450 \pm 4 mm

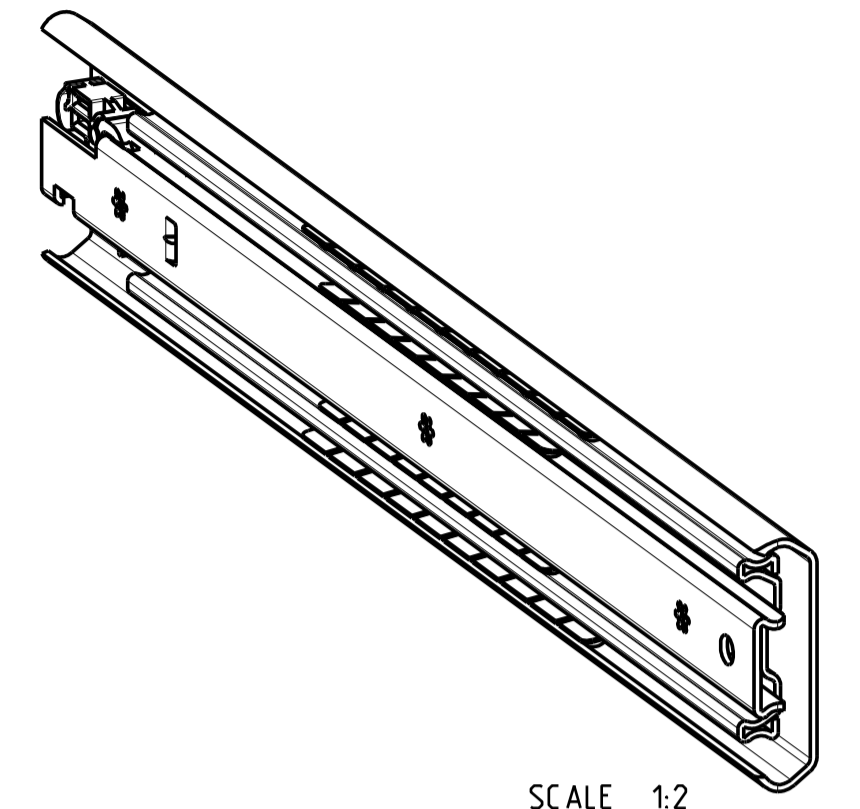
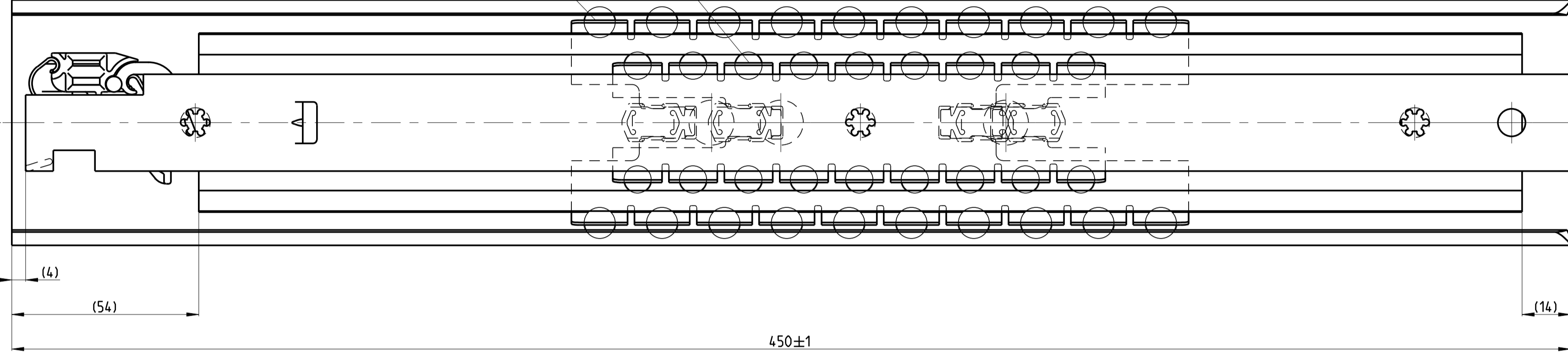
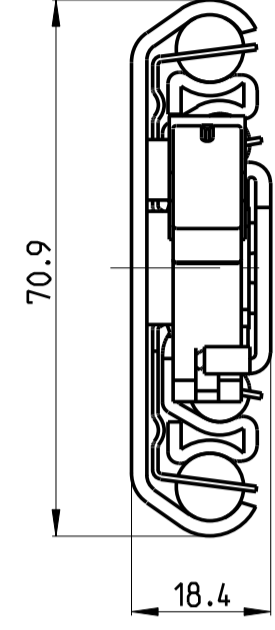

SCALE 1:2

FRONT

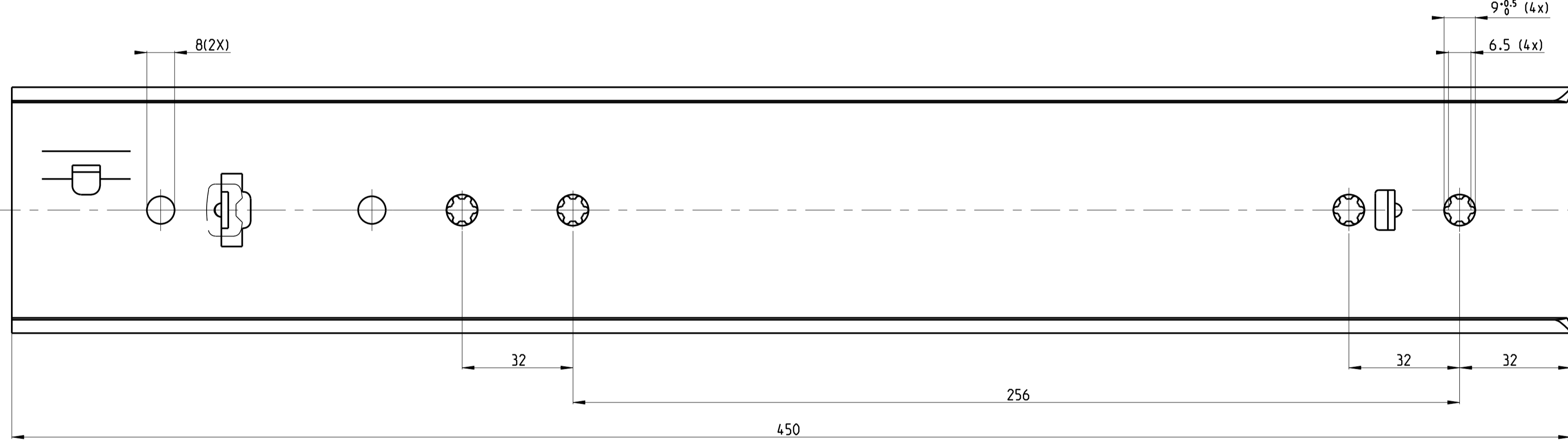
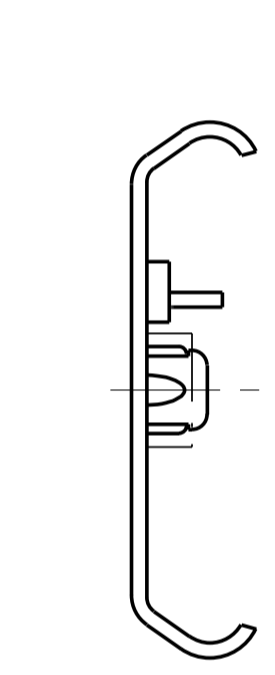

511-01-S64-TA1

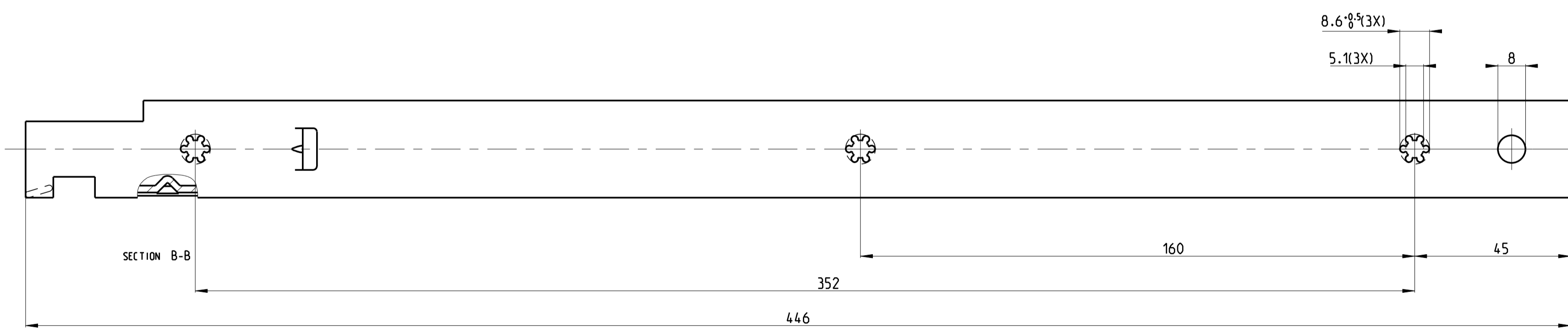
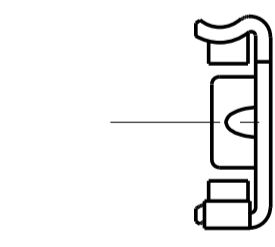

513-01-S64-TA3

SECTION B-B

PRO/ENGINEER Drawing Was: - 101-F94-02	Dimensions between marks are guide dimensions. Tolerances unless otherwise stated \pm 0.5mm.	Thomas Regout Int. B.V. reserves the right to alter non-customer specific specifications without notice.
American projection	DIMENSION mm	MAT.: -
SCALE 1:1	DATE 27-10-2011	REM.: RIGHT HAND SLIDE = LEFT HAND SLIDE
DESIGNER M. Mahieu	CHECKED -	Type F
TITAN 450.0 / 450.0 (18.5mm)		
THOMAS REGOUT INTERNATIONAL BV	Drw. Nr. 101-S64 _ 00	Format. A1
© Thomas Regout International BV All rights are reserved.		Production

04	-	-	05	-	-	06	-	-	-	-
01	-	-	02	-	-	03	-	-	-	-