

1	2	3	4	5	6
5	1	921948	02	FLEXFIT RUBBER-STOP	TPU DESMOPAN 487
4	2	914A38	00	CS HD SCREW DIN 7991 M5x12 A2-70	RVS A2-70
3	1	958-011	02	END STOP 1537 LOWER PLATE	AISI 304 (1.4301)
2	1	958-010	03	END STOP 1537 UPPER PLATE	AISI 304 (1.4301)
Item	Qty	Item number	Rev	Description	Material

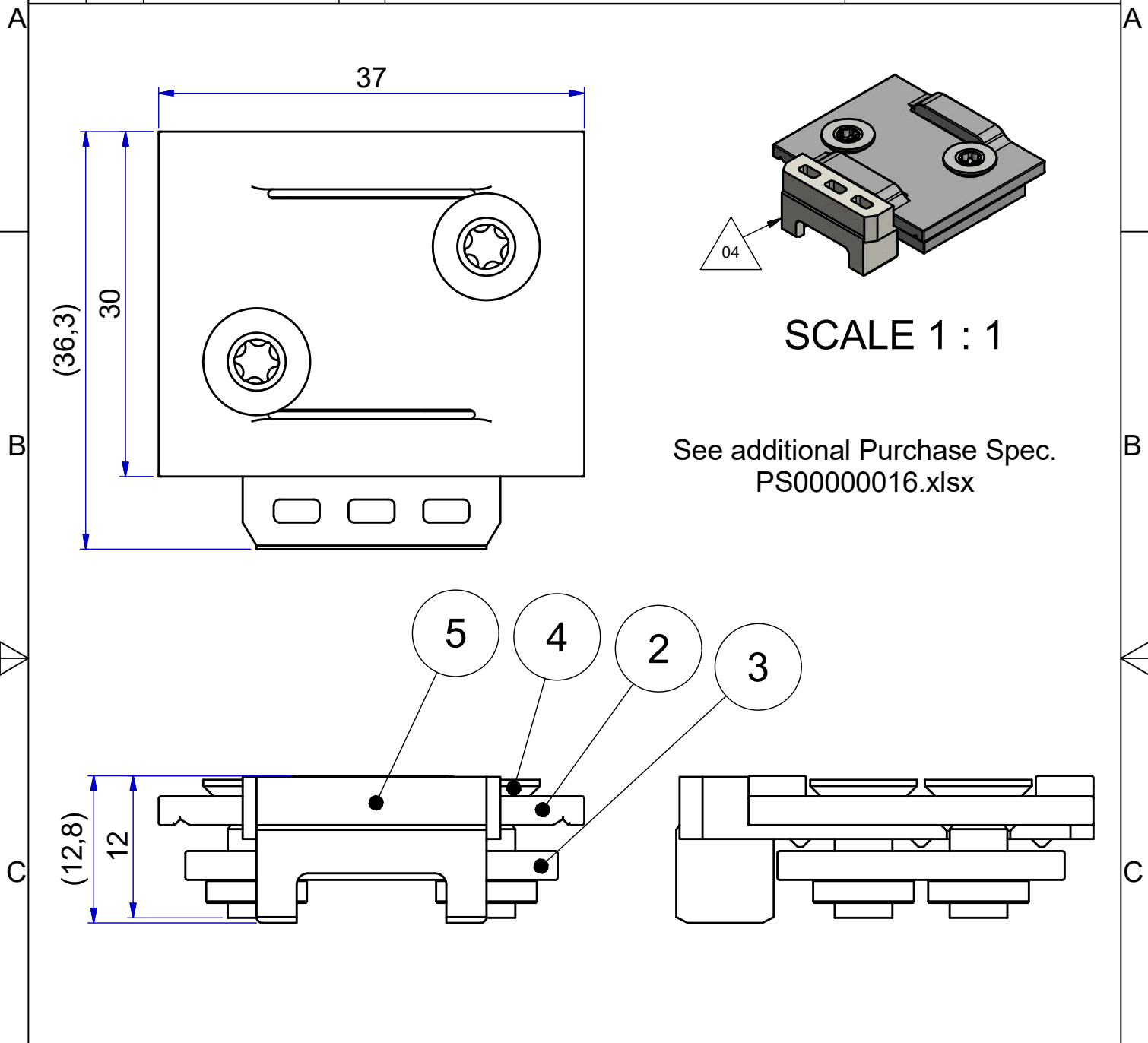

04	13-02-2020	Add Rubber Stop	R.Schreurs										
Rev	Date	Description	Designer										
Designer	R. Eijssen	Gen.Tol.Dim. $\pm 0,5$	Third angle projection										
Date	21-5-2014	Gen.Tol.Angle $\pm 0,5$											
Approver		Gen.Roughness Ra	<table border="1"> <tr> <td>Material</td> <td></td> </tr> <tr> <td>Treatment</td> <td></td> </tr> <tr> <td>Draw type</td> <td>Fabrication</td> </tr> <tr> <td>Scale</td> <td>2 : 1</td> </tr> <tr> <td>Type</td> <td></td> </tr> </table>	Material		Treatment		Draw type	Fabrication	Scale	2 : 1	Type	
Material													
Treatment													
Draw type	Fabrication												
Scale	2 : 1												
Type													
Date		Units mm/deg.	<table border="1"> <tr> <td>Doc.No.</td> <td>E000041410</td> </tr> <tr> <td>Model No.</td> <td>E000020910</td> </tr> </table>	Doc.No.	E000041410	Model No.	E000020910						
Doc.No.	E000041410												
Model No.	E000020910												

Description
FLEXFIT 1537 END STOP 30 MM
Released for Production

Format		Item No.	Revision
A4		205-S11	04