

5	1	921948	02	FLEXFIT RUBBER-STOP	TPU DESMOPAN 487
4	2	914A38	00	CS HD SCREW DIN 7991 M5x12 A2-70	RVS A2-70
3	1	958-013	03	END STOP 1529 LOWER PLATE	AISI 304 (1.4301)
2	1	958-012	03	END STOP 1529 UPPER PLATE	AISI 304 (1.4301)
Item	Qty	Item number	Rev	Description	Material

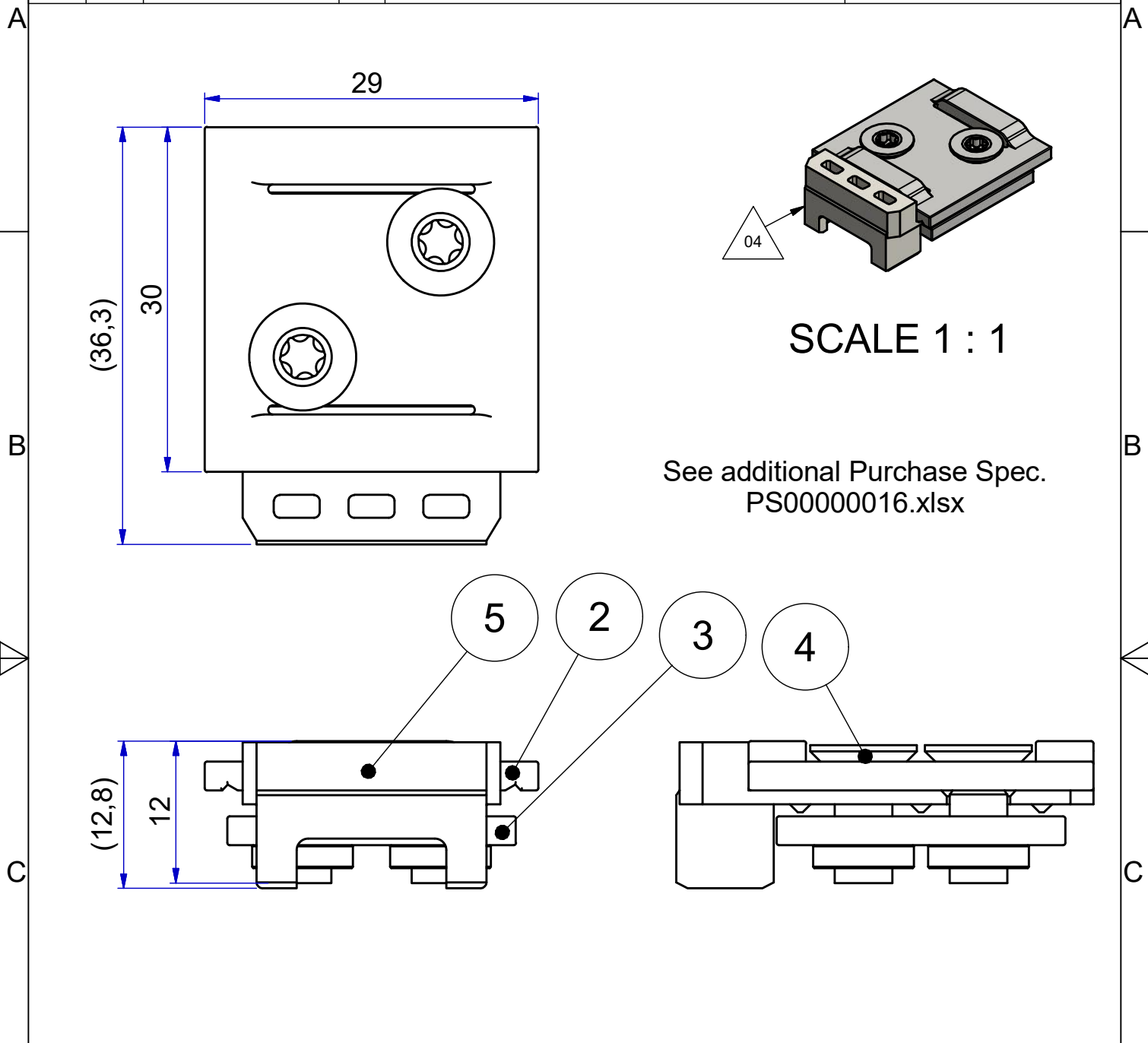

04	13-02-2020	Add Rubber Stop	R.Schreurs
Rev	Date	Description	Designer
Designer	J.Bastings	Gen.Tol.Dim. ± 0,5	Material
Date	23-3-2016	Gen.Tol.Angle ± 0,5	Treatment
Approver		Gen.Roughness Ra	Draw type Fabrication
Date		Units mm/deg.	Doc.No. E000041427
		Third angle projection	Scale 2 : 1
			Type
			Model No. E000041426

D FLEXFIT 1529 END STOP 30 MM

Released for Production

Format		Item No.	Revision
A4		205-S12	04