

T 1-2 = 7,244 in
T 2-3 = 8,504 in

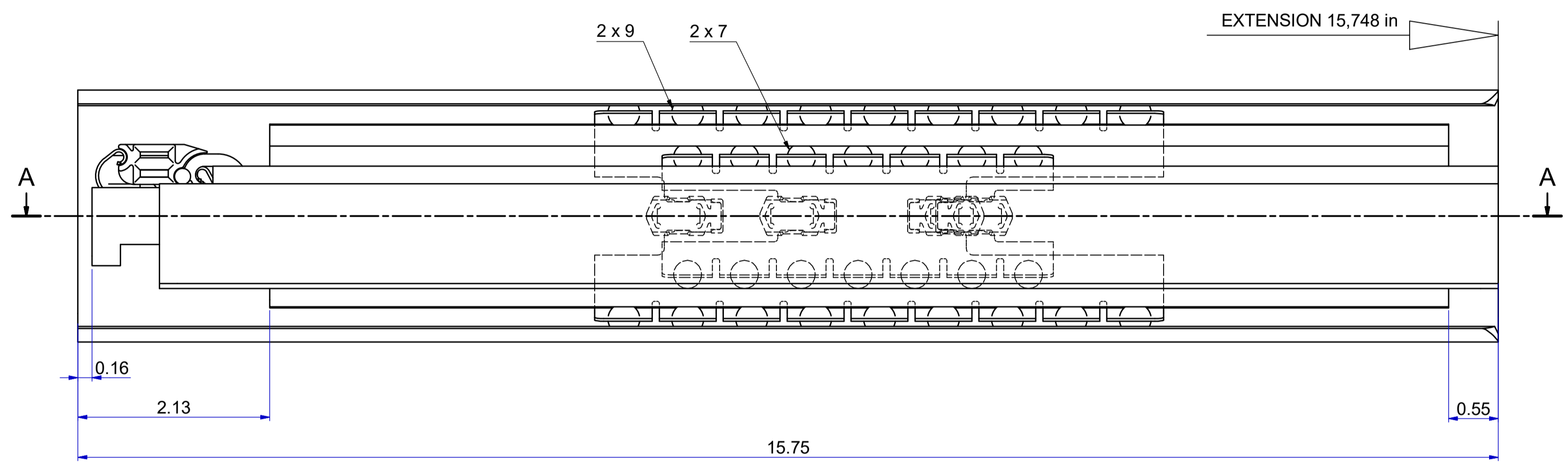

FRONT

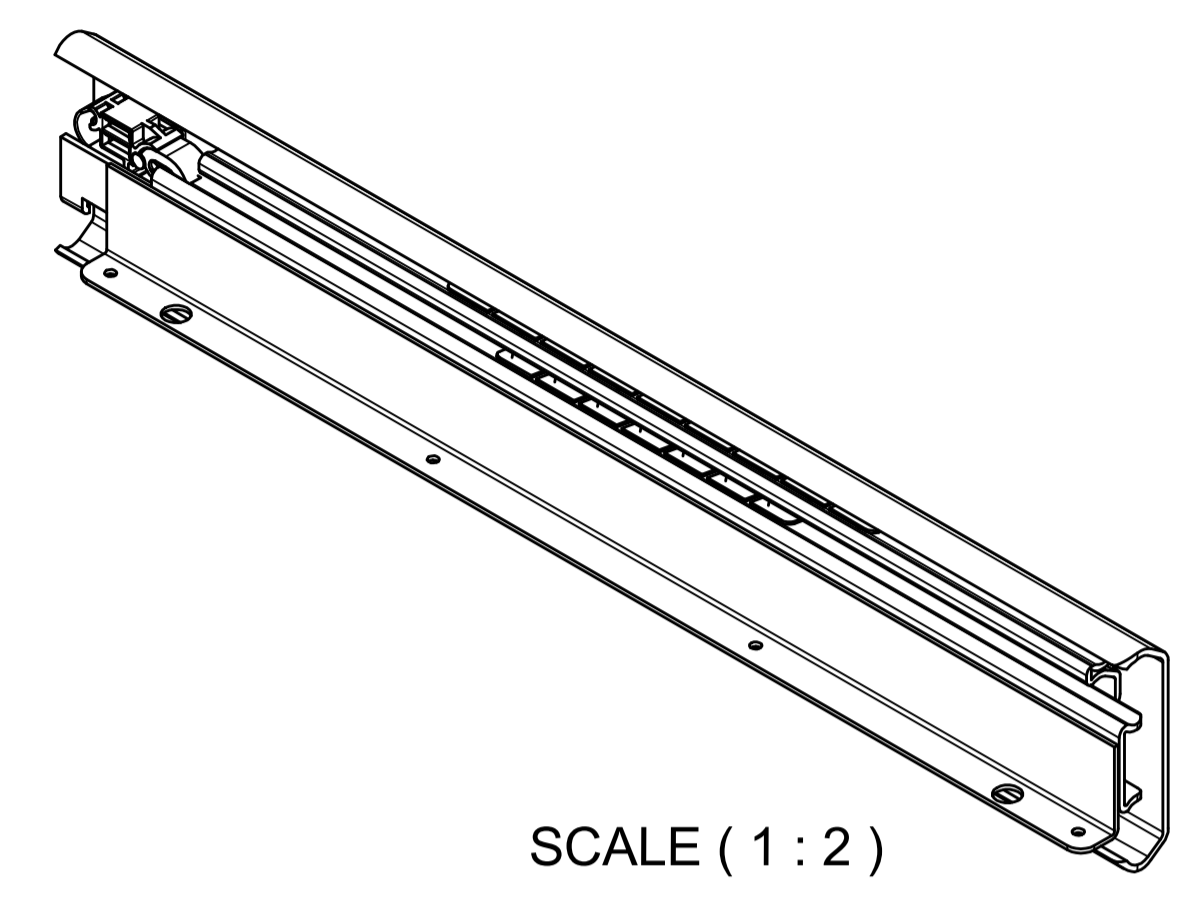
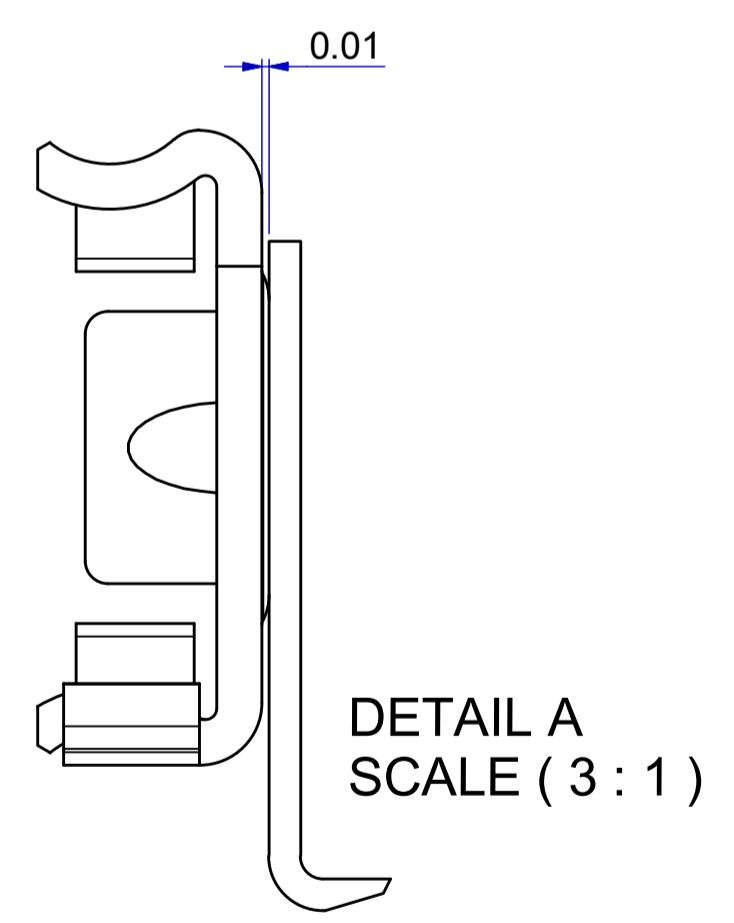
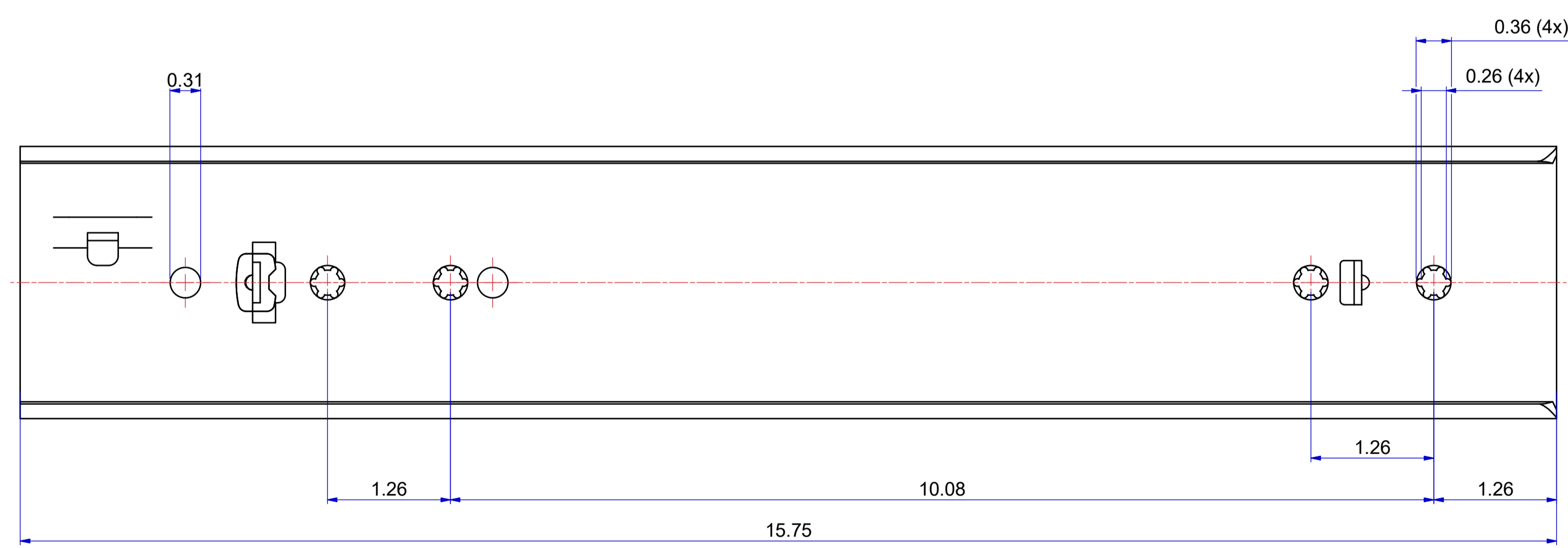
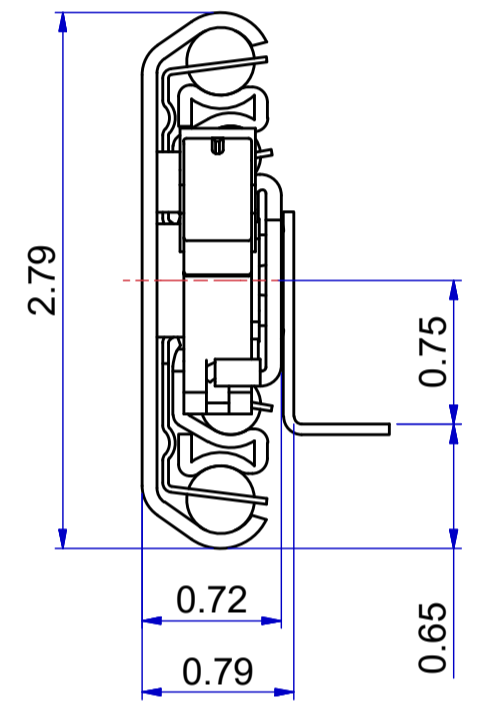

511-01-S43-TA1

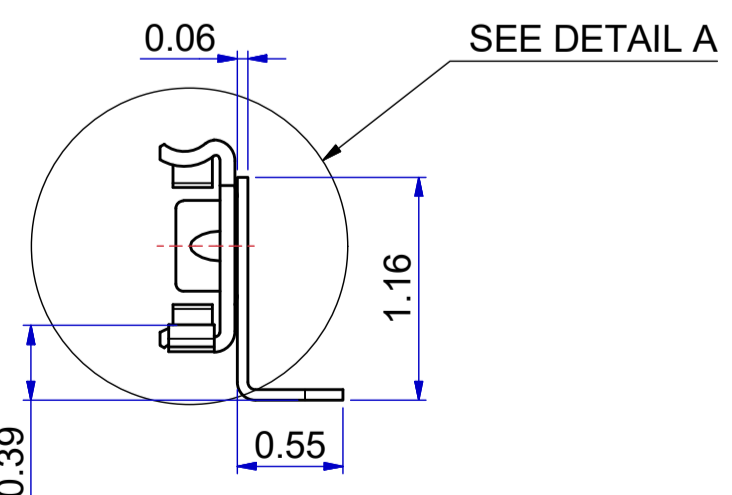

513-01-S43-TA3

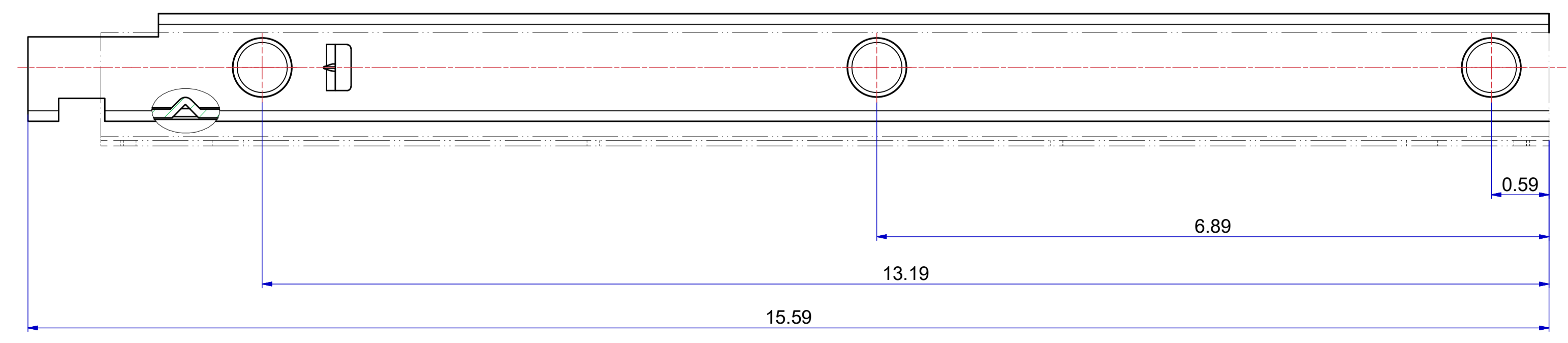

DIMENSIONS ARE CALCULATED FROM METRIC VALUES
THOMAS REGOUT B.V. RESERVES THE RIGHT TO ALTER NON-CUSTOMER SPECIFICATIONS WITHOUT NOTICE

Designer	D.Koper	Gen.Tol.Dim.	Third angle projection	Material	Generic
Date	26-10-2015	Gen.Tol.Angle		Treatment	
Approver		Gen.Roughness		Draw type	Fabrication
Date		Units	Inch/deg	Scale	1 : 1
				Type	Model No. E000036300

Description
TITAN 400 / 400 (18,4mm) [15.75"/15.75"(0724")]
Released for Production

Format	A1	Item No.	101-S43_Inch	Revision	00
--------	-----------	----------	---------------------	----------	-----------