

T 1-2 = 9,606 in
T 2-3 = 11,850 in

A-A (1:1)

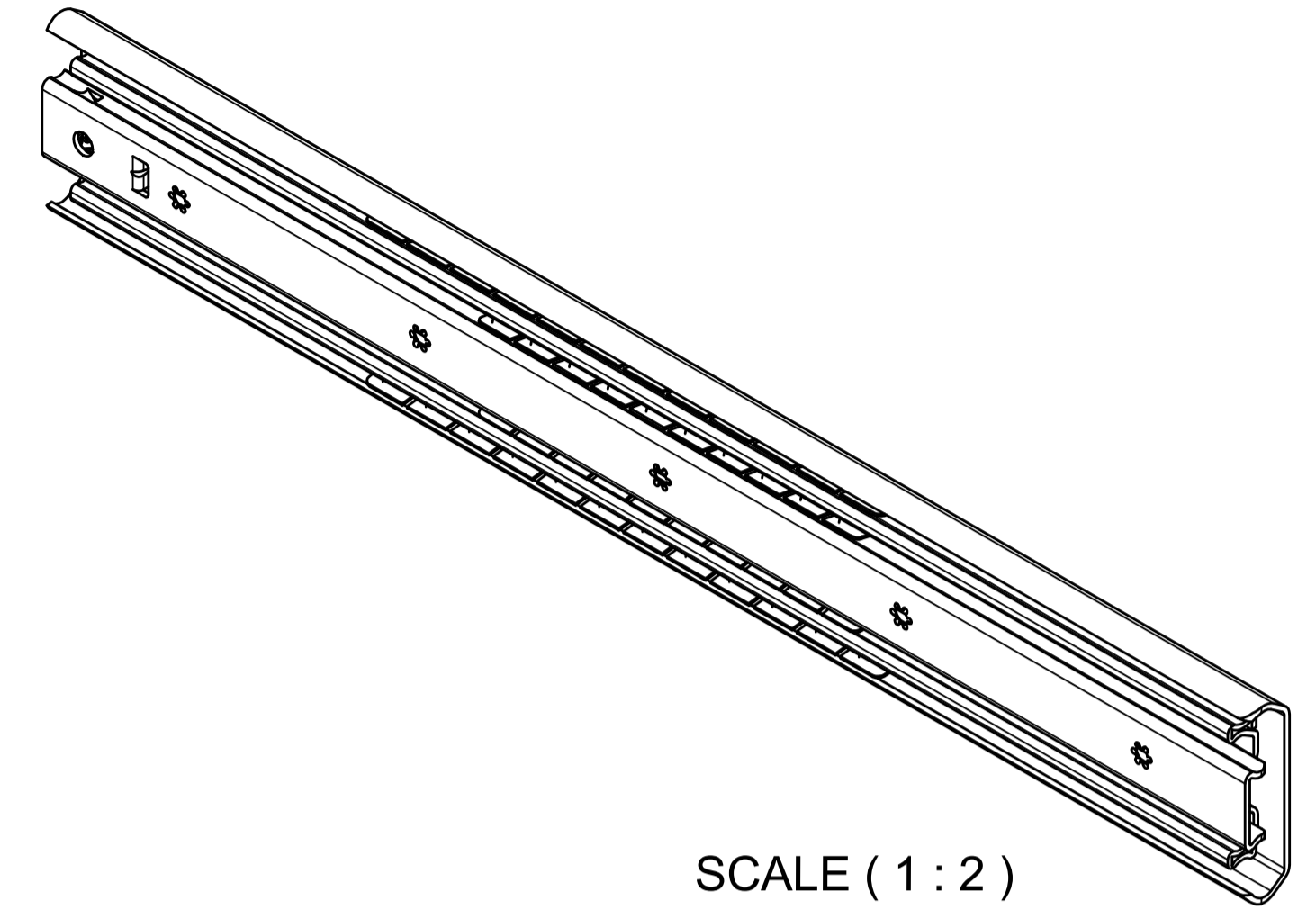

SCALE (1:2)

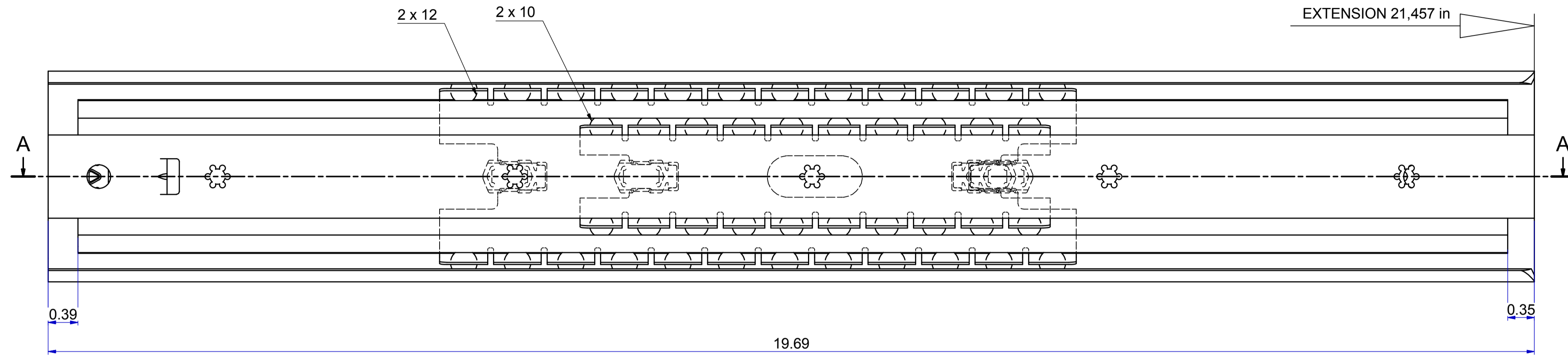
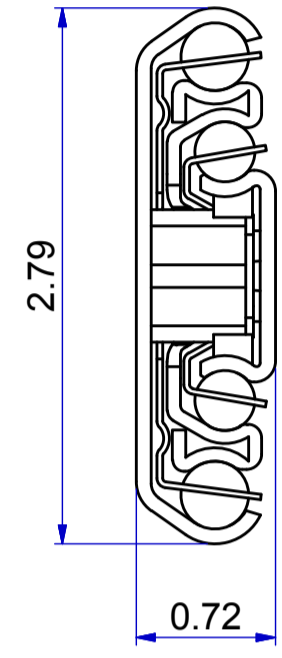
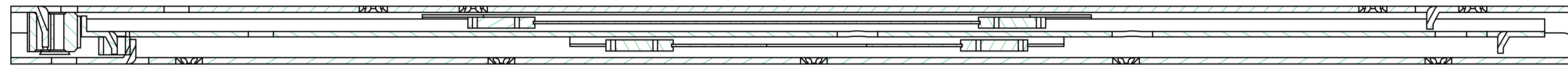
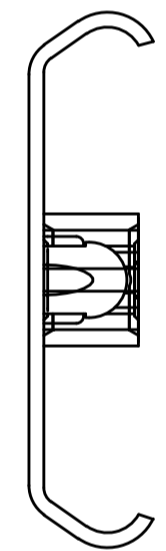

511-01-S25-TA1

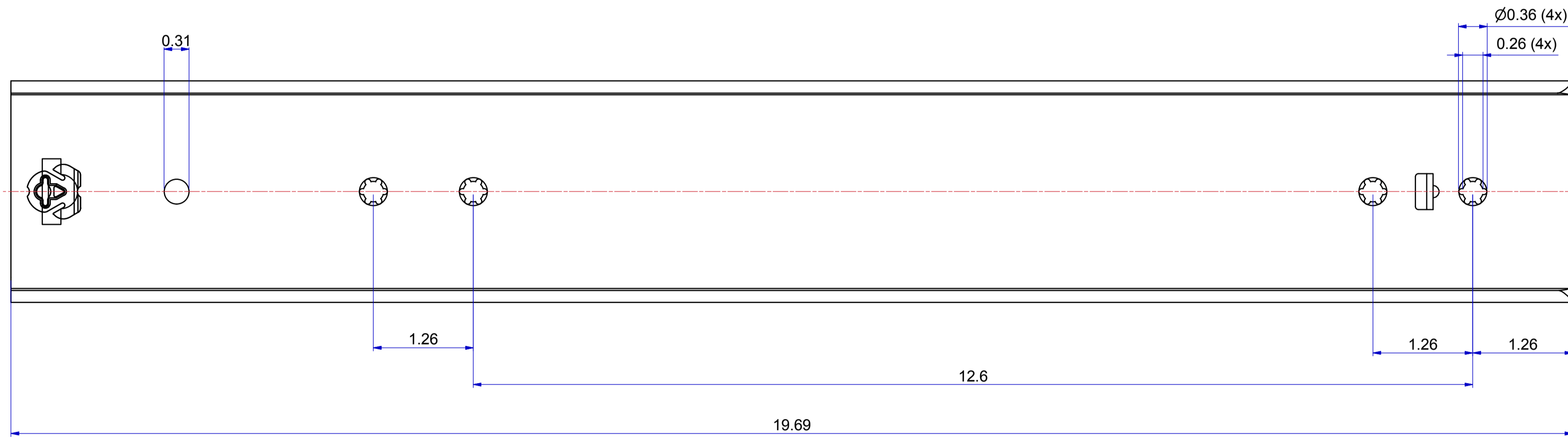

FRONT

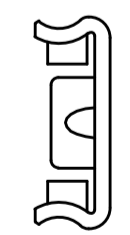

513-01-S25-TA3

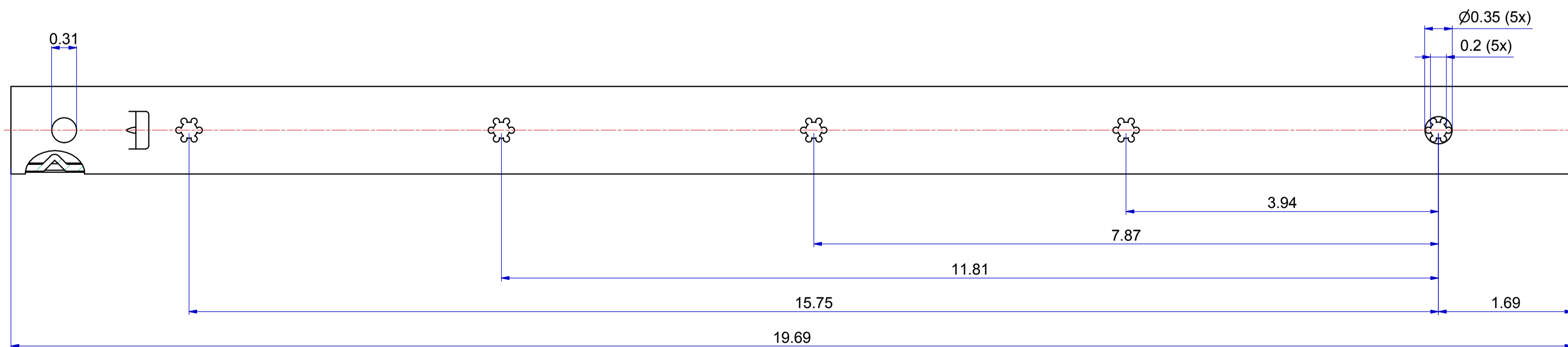

Released for Production

DIMENSIONS ARE CALCULATED FROM METRIC VALUES
THOMAS REGOUT B.V. RESERVES THE RIGHT TO ALTER NON-CUSTOMER SPECIFICATIONS WITHOUT NOTICE

Designer	Gen.Tol.Dim.	Third angle projection	Material	Generic
Date	26-10-2015	Gen.Tol.Angle	Treatment	
Approver	Gen.Roughness		Draw type	Fabrication
Date	Units		Inch/deg	Scale
			Type	Model No. E000036284

Description
TITAN 500 / 545 (18,4mm) [19.69"/21.46"(0.724")]
Released for Production

Format		Item No.	Revision
A1		101-S25_Inch	00