

T 1-2 = 9,055 in
T 2-3 = 10,630 in

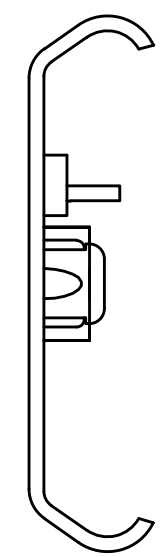

511-01-S45-TA1

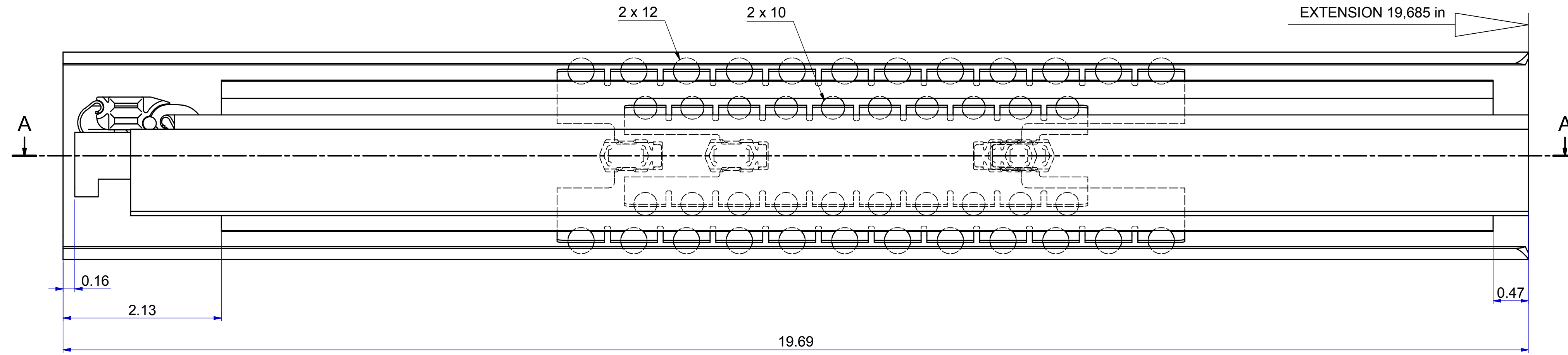
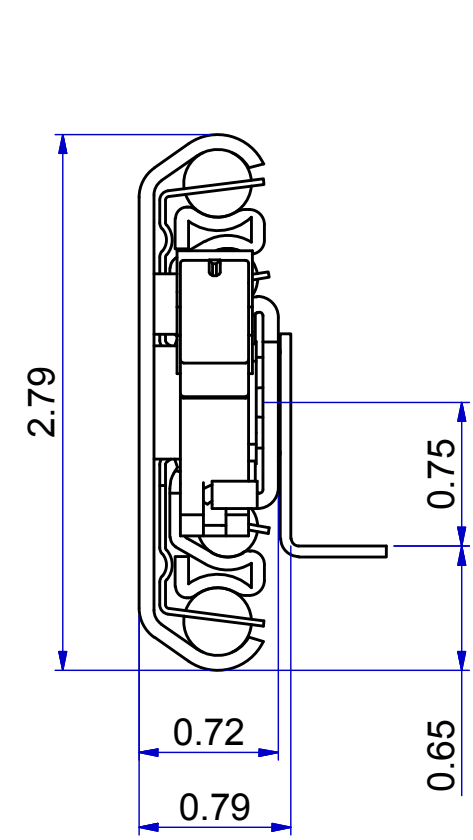
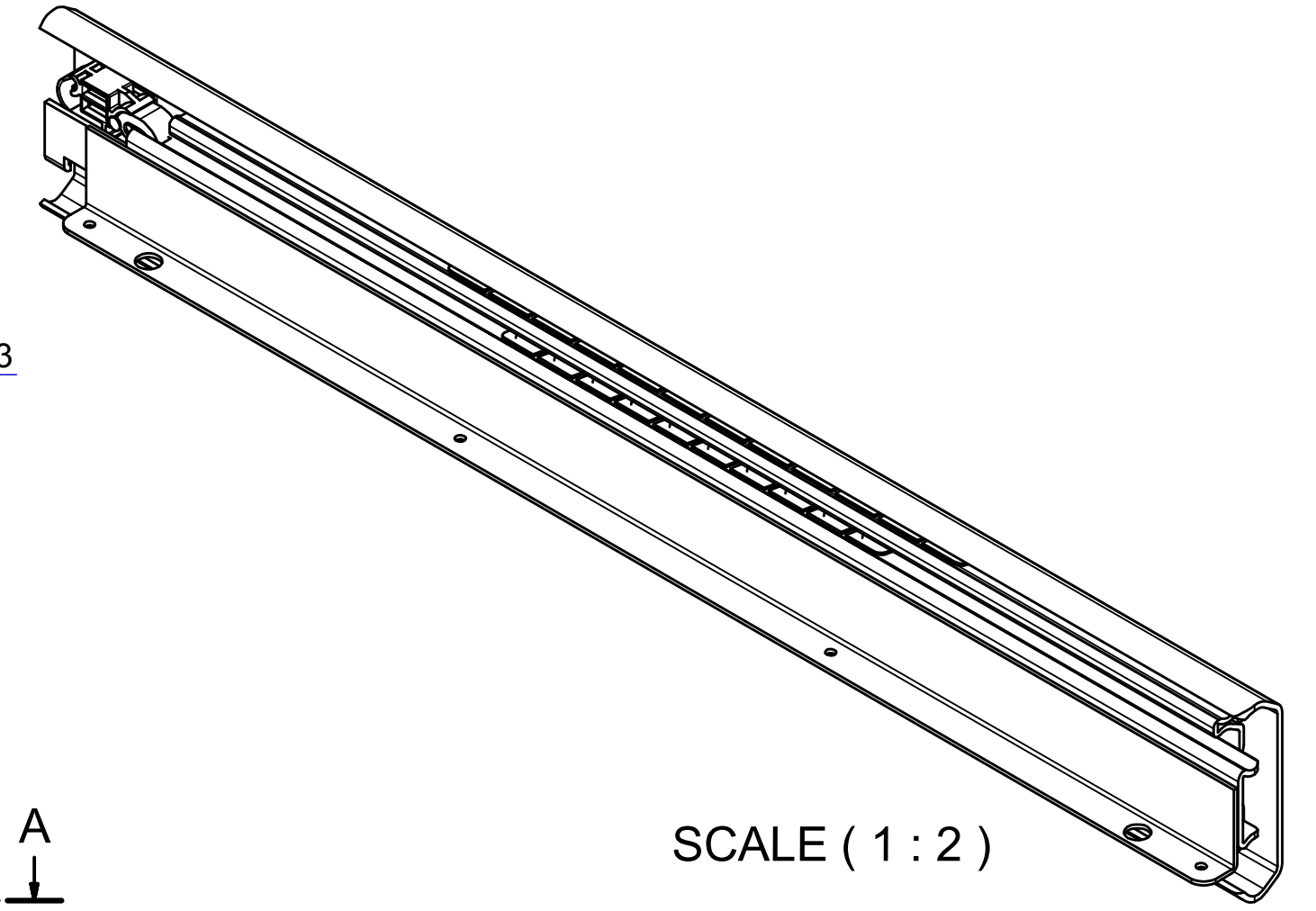
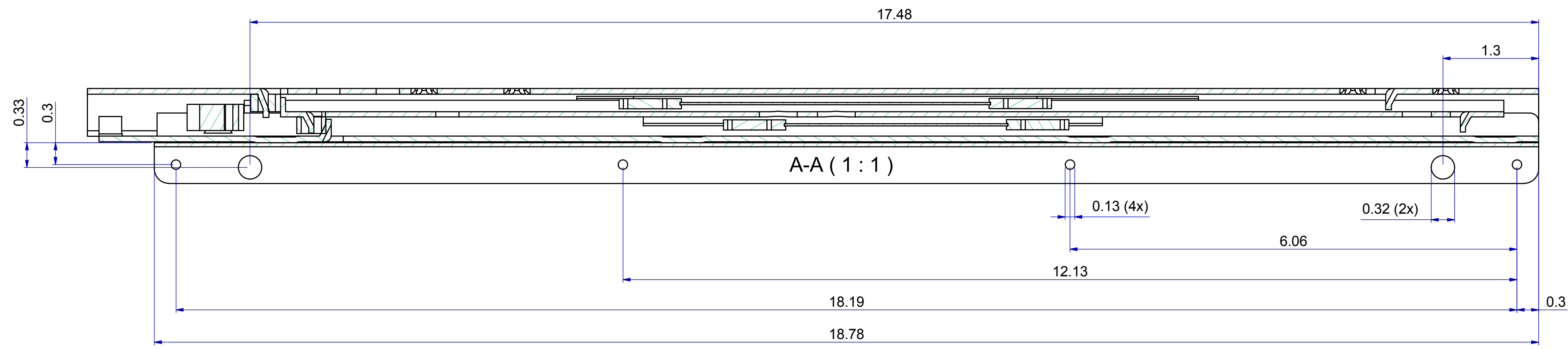
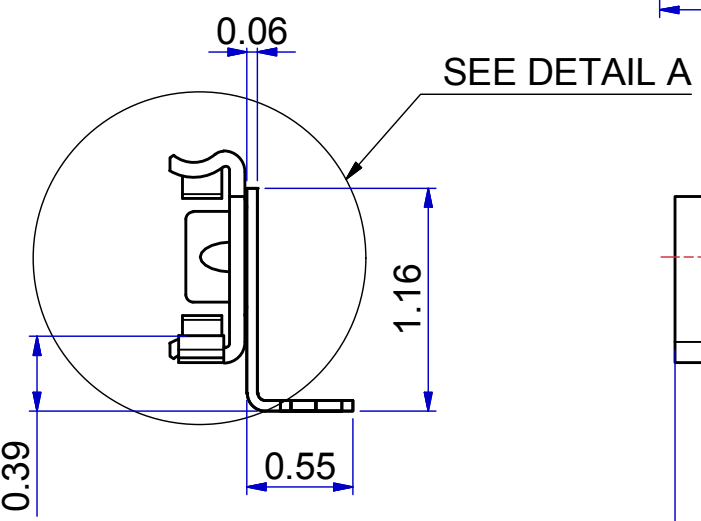
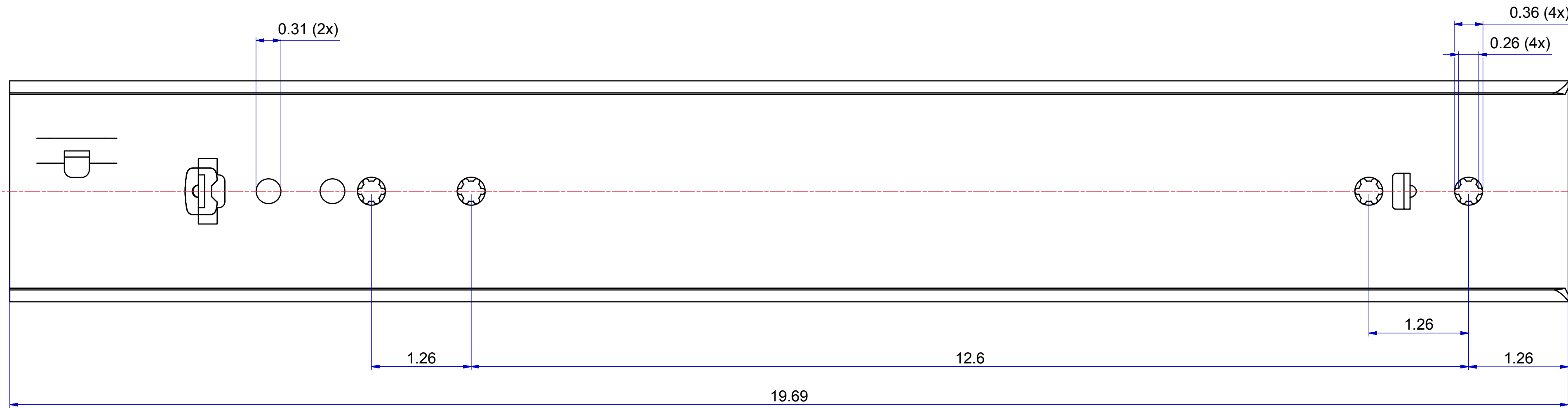

513-01-S45-TA3

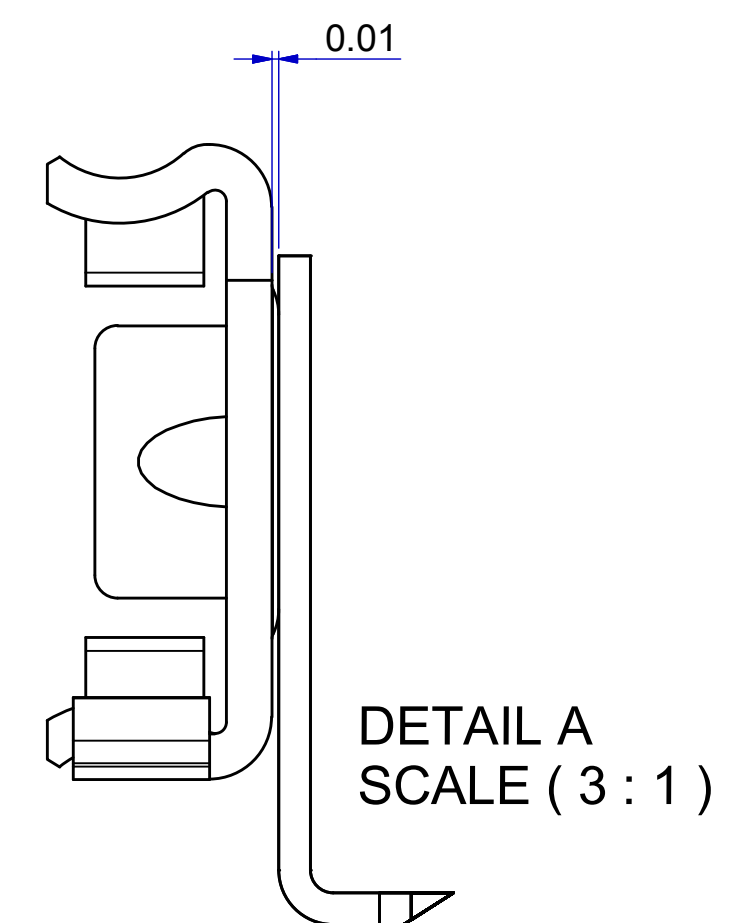
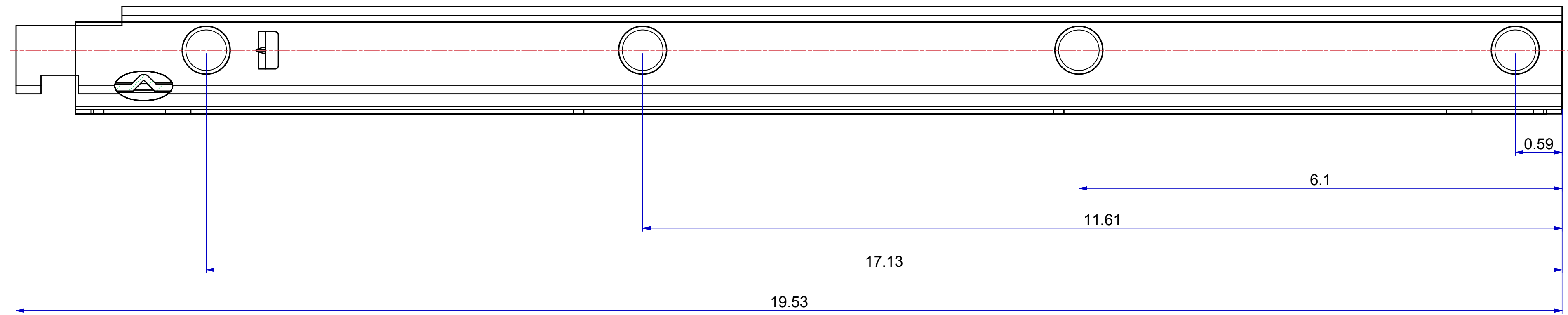

DIMENSIONS ARE CALCULATED FROM METRIC VALUES
THOMAS REGOUT B.V. RESERVES THE RIGHT TO ALTER NON-CUSTOMER
SPECIFICATIONS WITHOUT NOTICE

Designer: D.Koper	Gen.Tol.Dim.	Third angle projection	Material: Generic
Date: 26-10-2015	Gen.Tol.Angle		Treatment
Approver: Gen.Rougness			Draw type: Fabrication
Date	Units: Inch/deg	Scale: 1:1	Type: Model No. E000036304

Description
TITAN 500 / 500 (18,4mm) [19.69"/19.69"(0.724")]
Released for Production

Format: A1	THOMAS REGOUT INTERNATIONAL B.V.	Item No.: 101-S45_Inch	Revision: 00
------------	----------------------------------	------------------------	--------------