

T 1-2 = 10,866 in  
T 2-3 = 12,559 in

EXTENSION 23,425 in

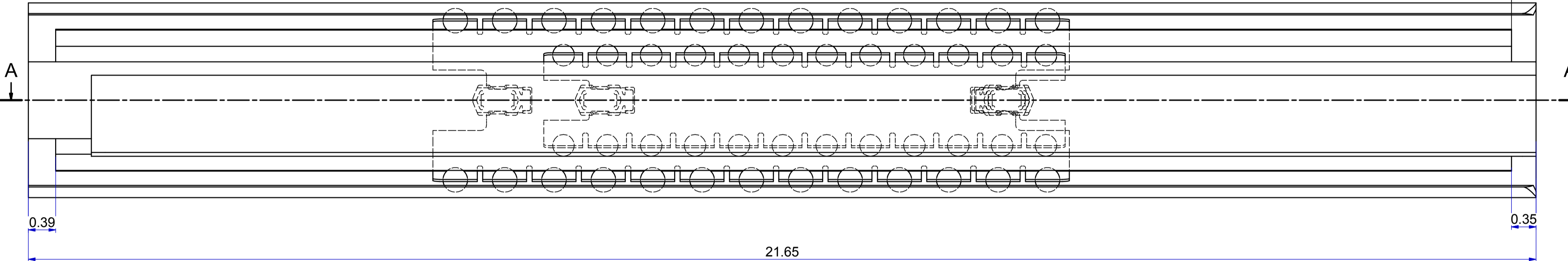

FRONT

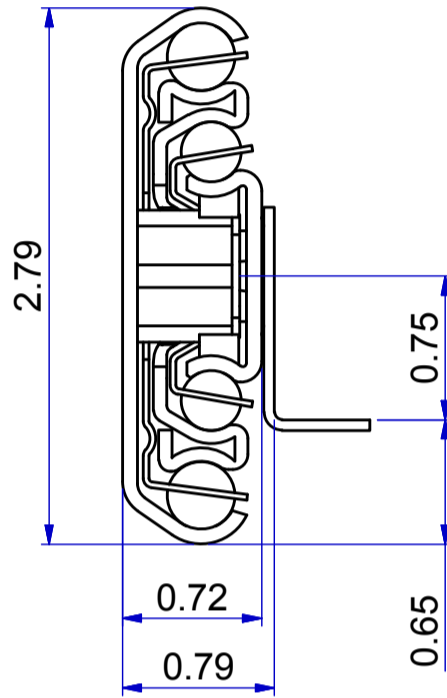
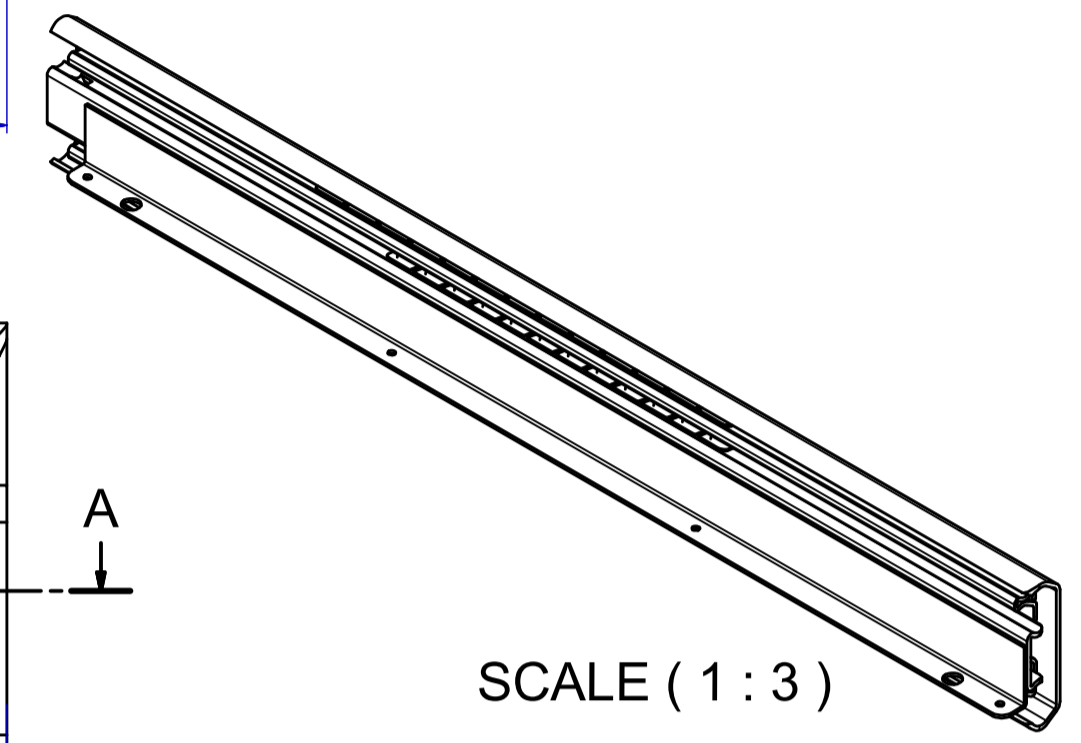
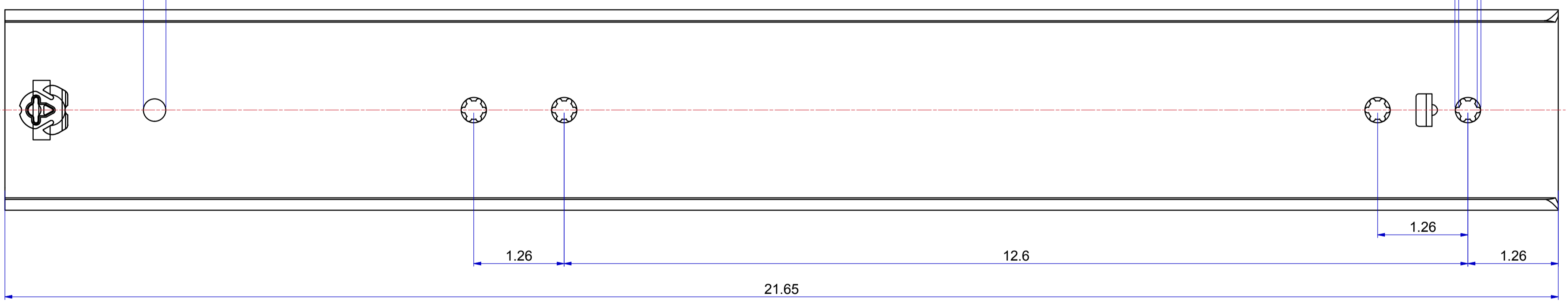

511-01-S06-TA1

SEE DETAIL A

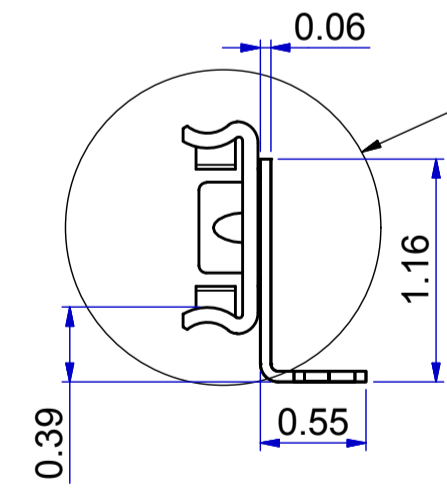

513-01-S06-TA3

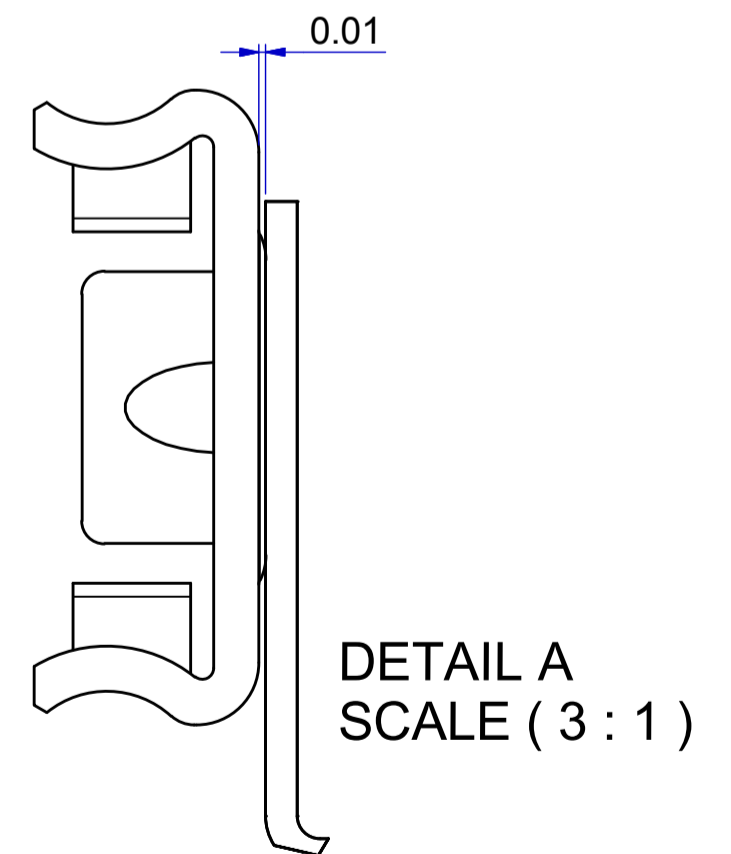
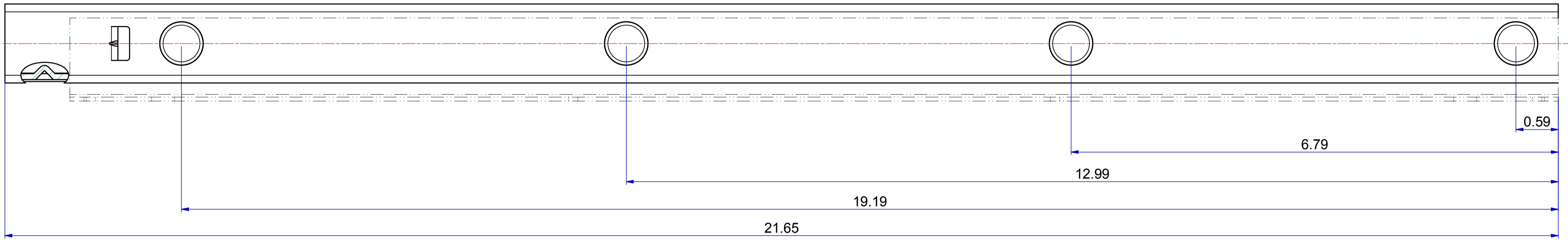

Released for Production

DIMENSIONS ARE CALCULATED FROM METRIC VALUES  
THOMAS REGOUT B.V. RESERVES THE RIGHT TO ALTER NON-CUSTOMER SPECIFICATIONS WITHOUT NOTICE

Designer	Gen.Tol.Dim.	Third angle projection	Material	Generic
Date	23-10-2015	Gen.Tol.Angle	Treatment	
Approver	Gen.Roughness		Draw type	Fabrication
Date	Units		Inch/deg	Scale
Description			Type	Model No.
TITAN 550 / 595 (18,4mm) [21.65"/23.43"(0.724")]			Scale	1:1
Format			Item No.	Revision
A1			THOMAS REGOUT INTERNATIONAL B.V.	101-S06_Inch 00
© THOMAS REGOUT INTERNATIONAL BV, Industrieweg 40, 6219 NR, Maastricht, The Netherlands, +31 (0)43 351 66 66 All rights are reserved.				