

A-A (1:1)

T 1-2 = 10,866 in  
T 2-3 = 12,559 in

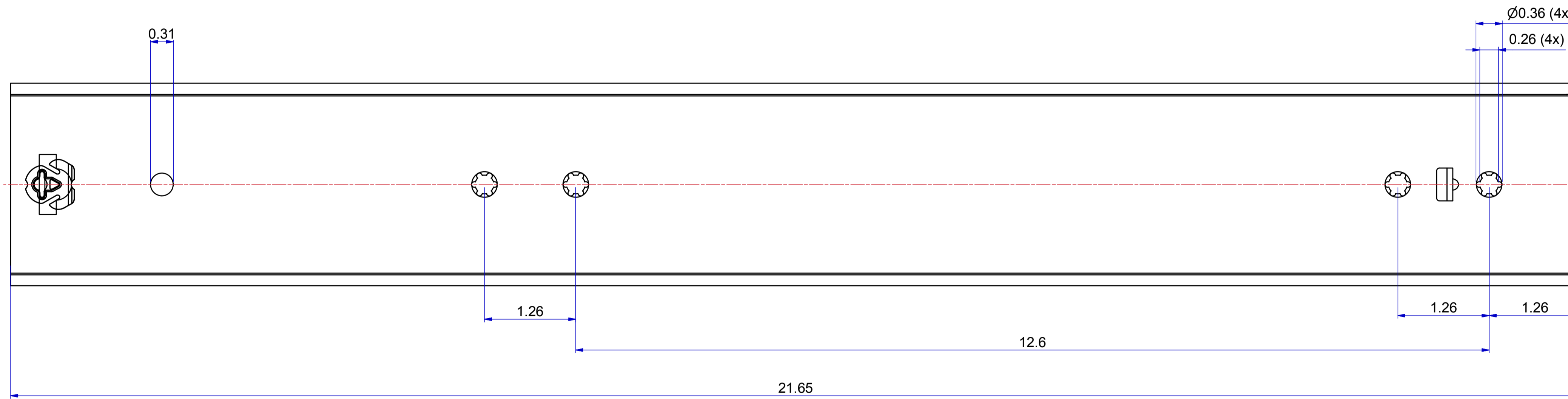

511-01-S26-TA1

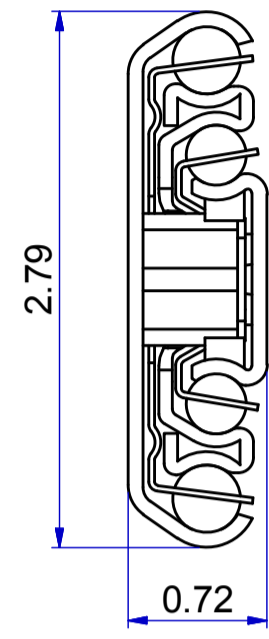
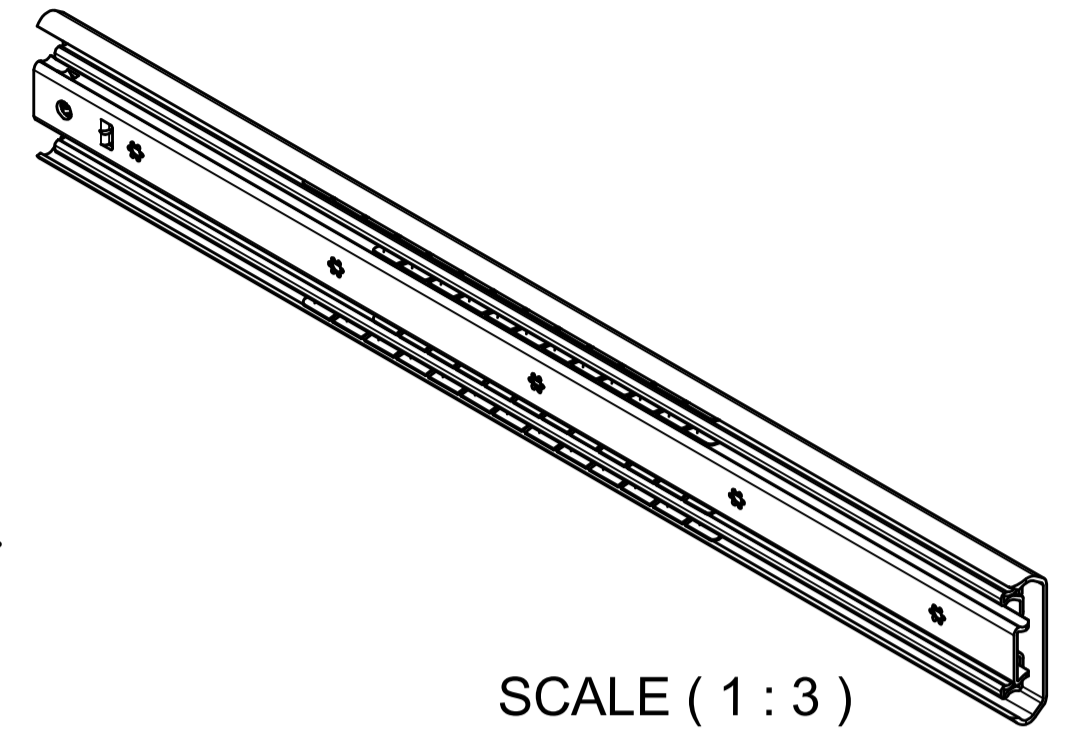
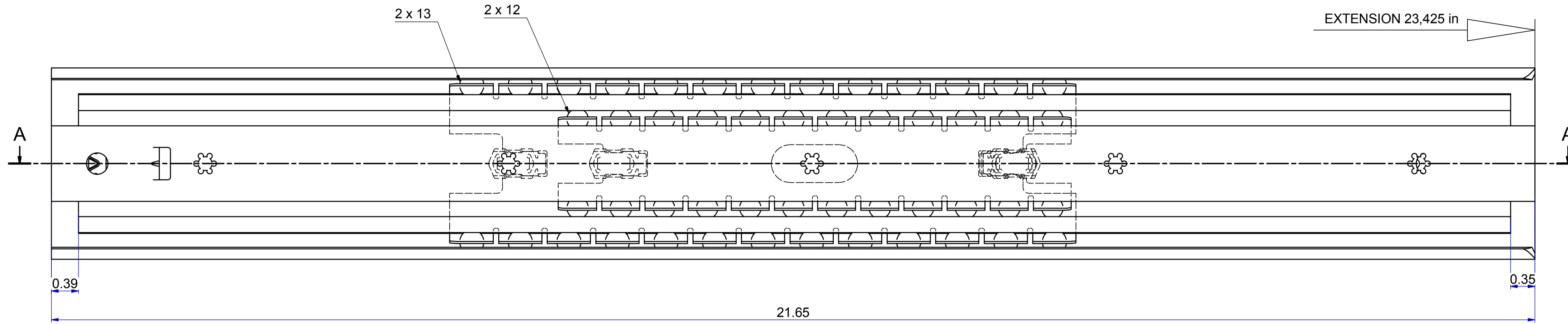
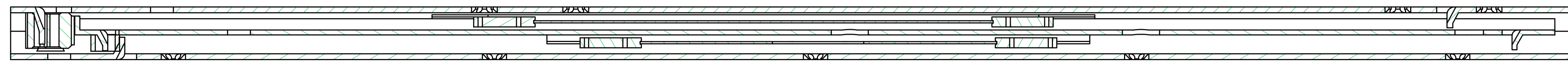
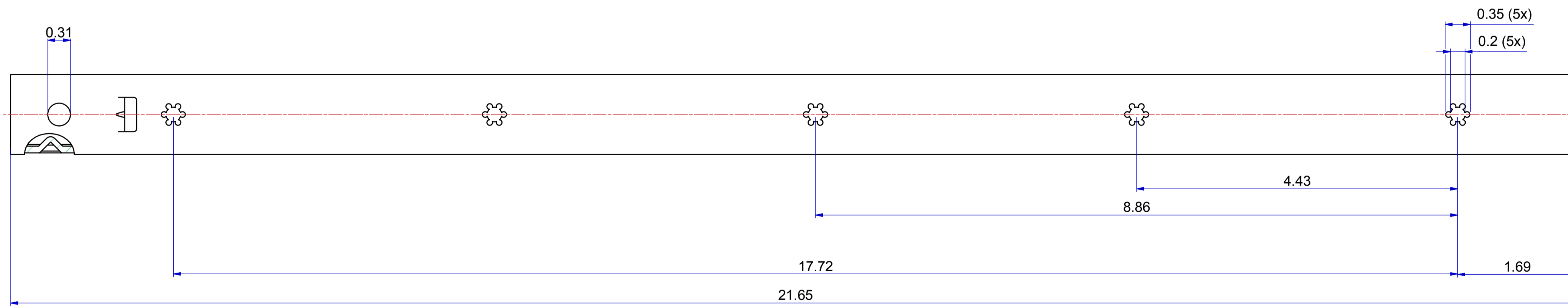

513-01-S26-TA3

Released for Production

DIMENSIONS ARE CALCULATED FROM METRIC VALUES  
THOMAS REGOUT B.V. RESERVES THE RIGHT TO ALTER NON-CUSTOMER SPECIFICATIONS WITHOUT NOTICE

Designer	Gen.Tol.Dim.	Third angle projection	Material	Generic
Date	26-10-2015	Gen.Tol.Angle	Treatment	
Approver	Gen.Roughness		Draw type	Fabrication
Date	Units		Inch/deg	Scale
			Type	Model No. E000036286

Description  
TITAN 550 / 595 (18,4mm) [21.65"/23.43"(0.724")]  
Released for Production

Format	A1	THOMAS REGOUT INTERNATIONAL B.V.	Item No.	101-S26_Inch	Revision	00
--------	----	----------------------------------	----------	--------------	----------	----