

T 1-2 = 20,236 in
T 2-3 = 21,102 in

A-A (1:1)

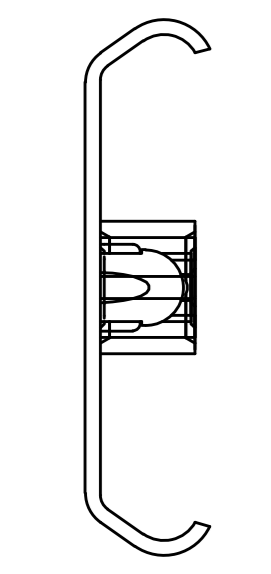

511-01-S31-TA1

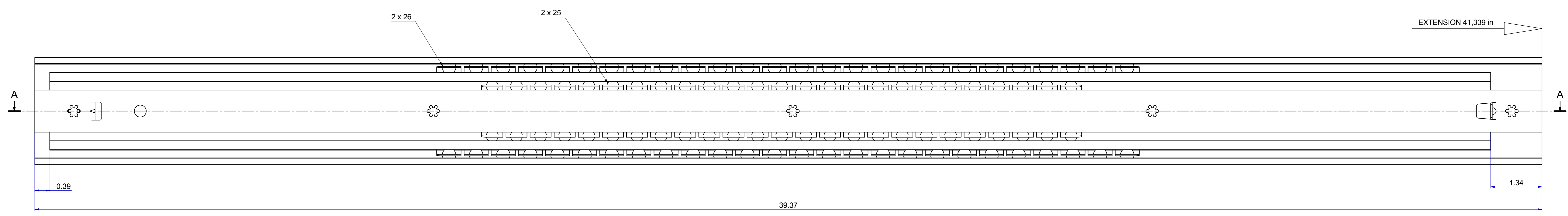
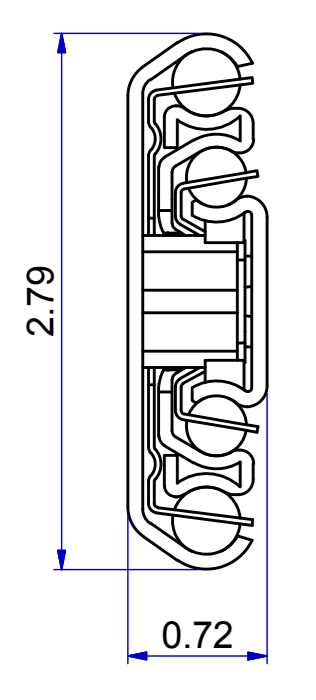
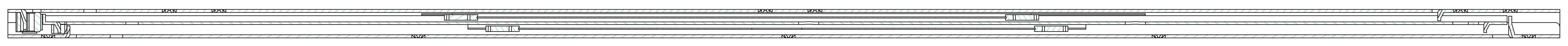
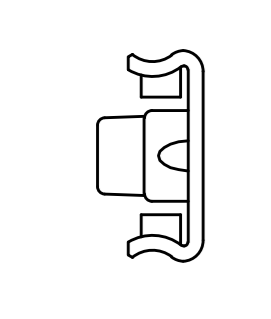
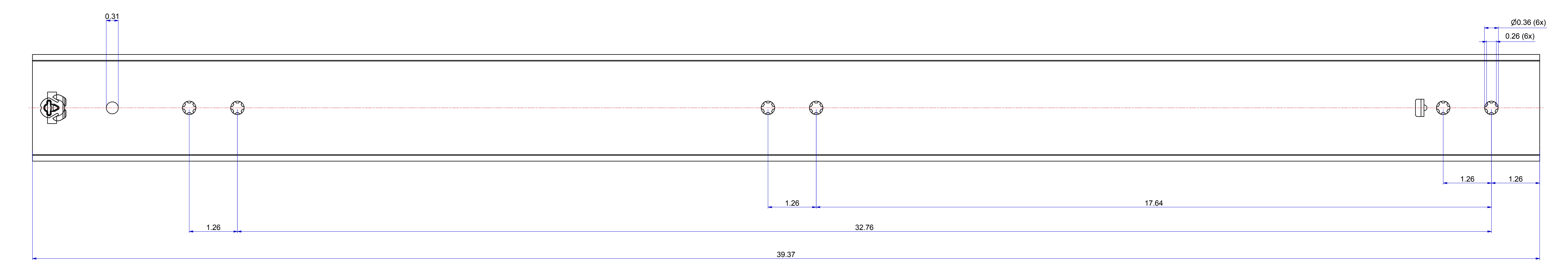

513-01-S31-TA3

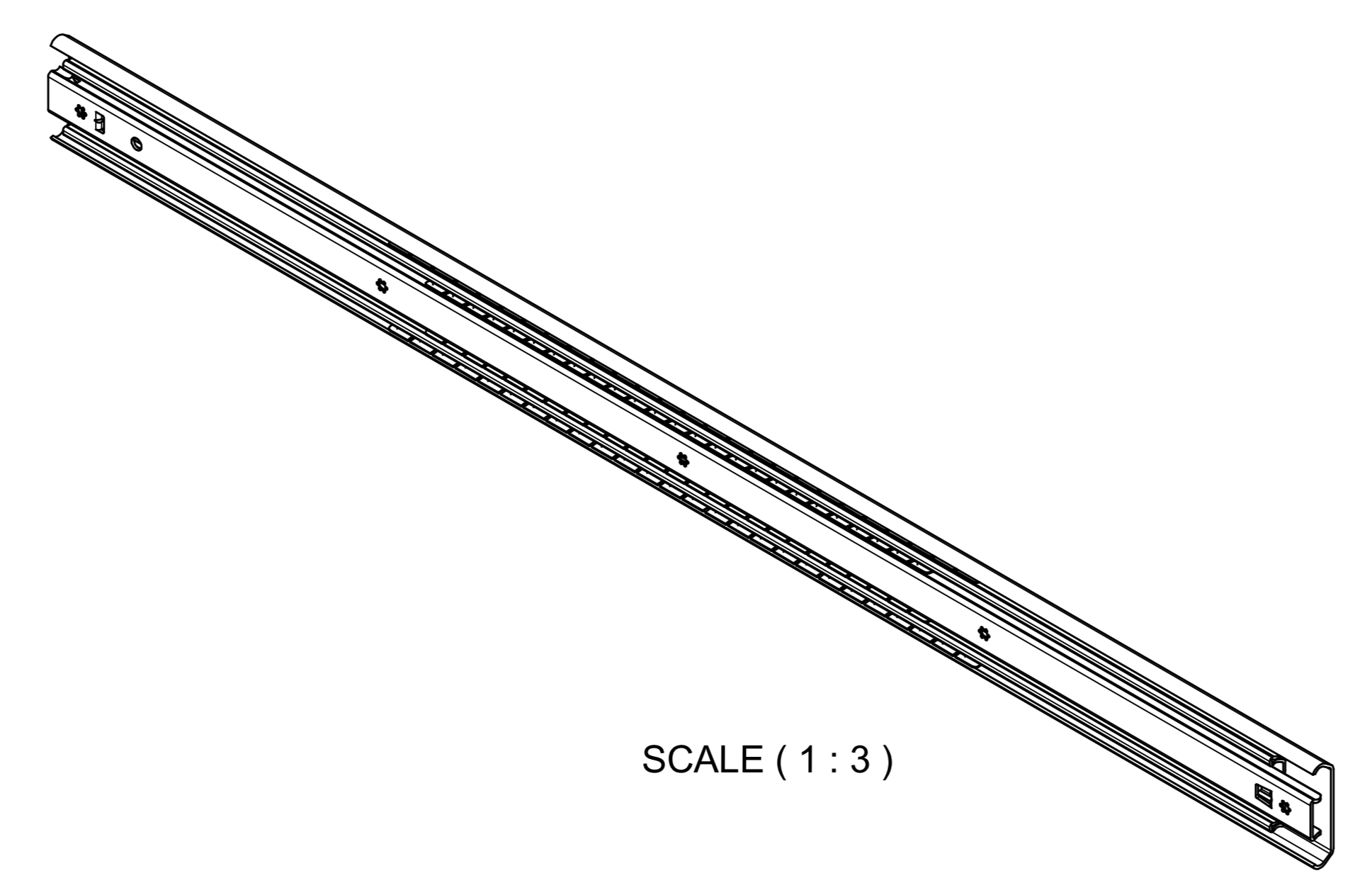
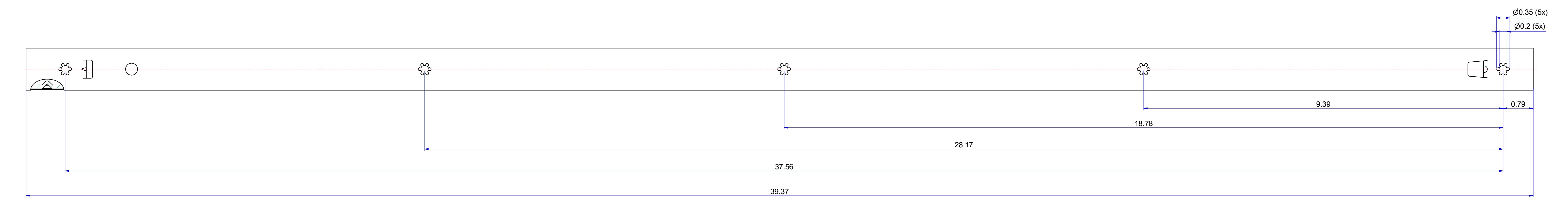

SCALE (1:3)

Released for Production

DIMENSIONS ARE CALCULATED FROM METRIC VALUES
THOMAS REGOUT B.V. RESERVES THE RIGHT TO ALTER NON-CUSTOMER
SPECIFICATIONS WITHOUT NOTICE

Designer	Gen.Tol.Dim.	Third angle projection	Material	Generic
Date	26-10-2015	Gen.Tol.Angle	Treatment	
Approver	Gen.Roughness	Scale	Draw type	Fabrication
Date	Units	Inch/deg	Scale	1:1
Description		Units	Type	Model No.
TITAN 1000 / 1050 (18,4mm) [39.37"/41.34"(0.724")]		Units	Type	Model No.

Format	A0	THOMAS REGOUT INTERNATIONAL B.V.	Item No.	101-S31_Inch	Revision	00
© THOMAS REGOUT INTERNATIONAL B.V., Industrieweg 40, 6219 NR, Maastricht, The Netherlands, +31 (0)43 353 66 66 All rights are reserved.						