

T 1 - 2 = 8.82

A-A

EXTENSION 8.82  
±.08  
2 x 7

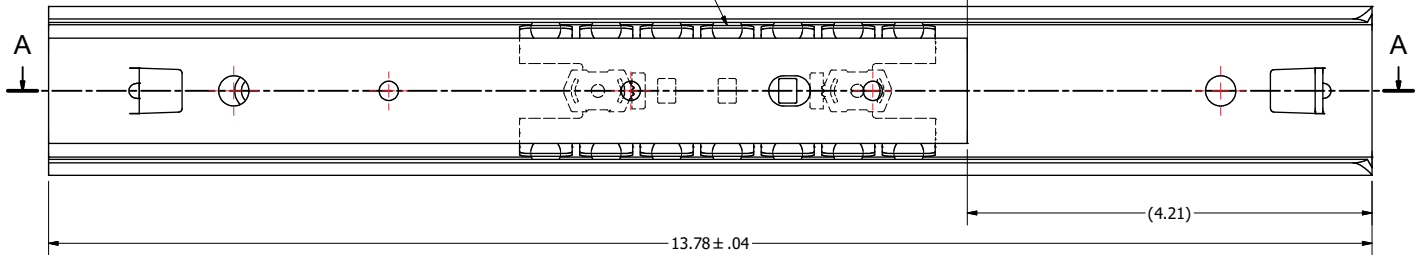
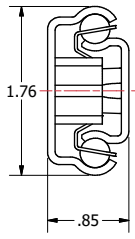

NOT FOR CUSTOMER APPLICATION!

NOT FOR CUSTOMER APPLICATION!

FRONT

∅.41<sup>+.02</sup><sub>-.00</sub> (3x)  
∅.28 (3x)

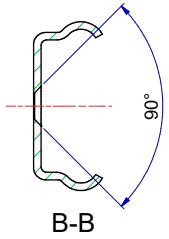

B-B

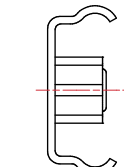

511-05-A42-ADO1

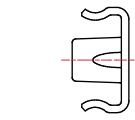
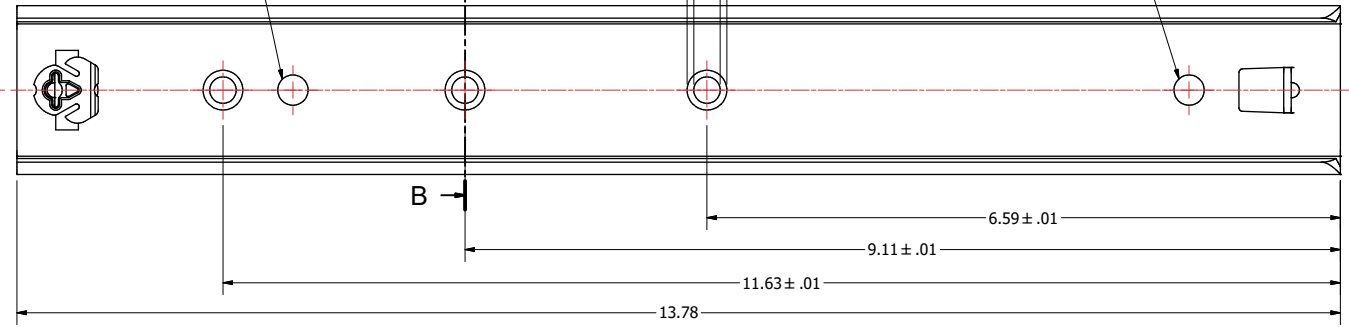

513-05-A42-TB3

NOT FOR CUSTOMER APPLICATION!

∅.20 ± .004 (3x)

Right hand slide = Left hand slide.

Dimensions between marks are guide dimensions.

Thomas Regout Int. B.V. reserves the right to alter non-customer specific specifications without notice.

# Released for Production

DIMENSIONS ARE CALCULATED FROM METRIC VALUES  
THOMAS REGOUT INT. BV. RESERVES THE RIGHT TO  
ALTER NON-CUSTOMER SPECIFICATIONS WITHOUT NOTICE

|                     |                        |                        |                       |                    |
|---------------------|------------------------|------------------------|-----------------------|--------------------|
| Designer L. Hermans | Gen.Tol.Dim. ± 0.0197  | Third angle projection | Material              |                    |
| Date 24-8-1993      | Gen.Tol.Angle ± 0.0197 |                        | Treatment             |                    |
| Approver            | Gen.Roughness Ra       |                        | Draw type Fabrication | Doc.No. E000150408 |
| Date                | Units inch/deg.        |                        | Scale 1 : 1           | Type               |

Description  
**ADO 350/224mm (21.5) [13.78"/8.82" (0.85")]**

|                         |  |                  |             |
|-------------------------|--|------------------|-------------|
| Format A2               |  | Item No. 105-042 | Revision 03 |
| Released for Production |  |                  |             |

© THOMAS REGOUT INTERNATIONAL BV, Industrieweg 40, 6219 NR, Maastricht, The Netherlands, +31 (0)43 351 66 66 All rights are reserved.

| Rev | Date       | Description   | Designer |
|-----|------------|---|----------|
| 03  | 28-7-2023  | 513-05-042-TB3; SLEUFGAT TOEGEVOEGD VLGS. AGR 231345; GEMAAKT IN INVENTOR | R.G      |
| 03  | 10-02-2008 | Gat 8mm op 40mm voorkant toegevoegd                                       | M.Lamkin |
| 02  | 05-06-2007 | Ankersluitrubber toegepast ivm met automatische montage (geen sluiting)   | M.Bulté  |
| 01  | 13-12-2005 | Tekening in ProE gezet + ophanggat AK 1-profiel vervalt                   | M.Bulté  |