

T 1 - 2 = 9,409 in

C-C (1:1)

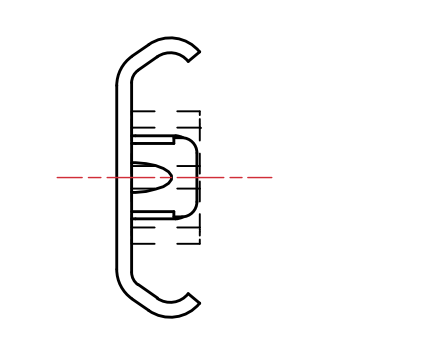

511-07-240-FA1

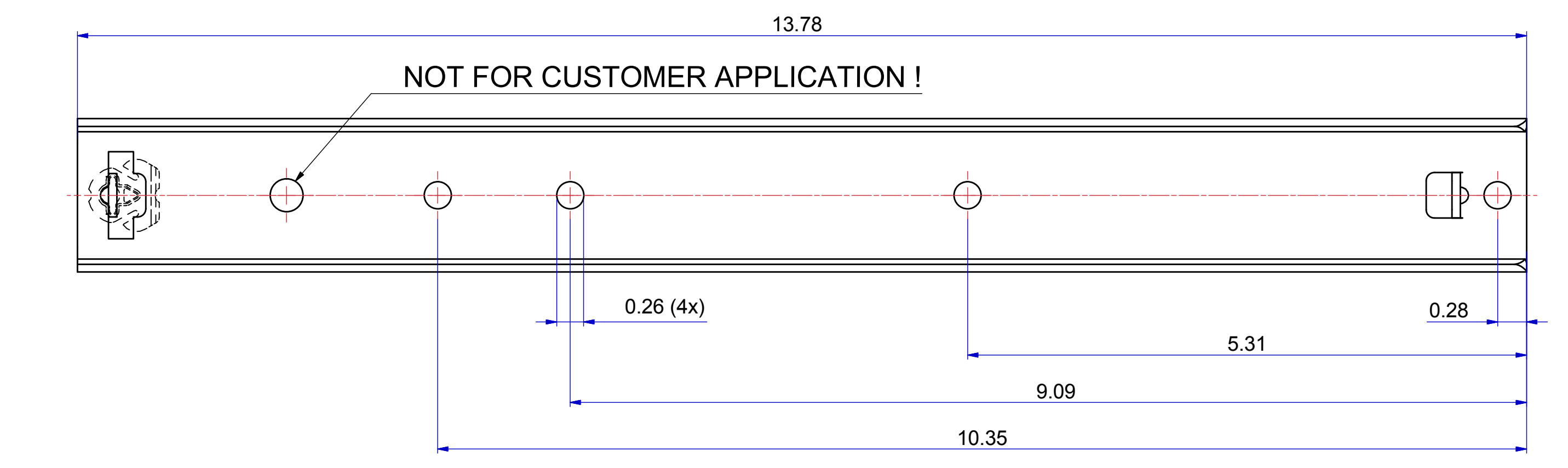
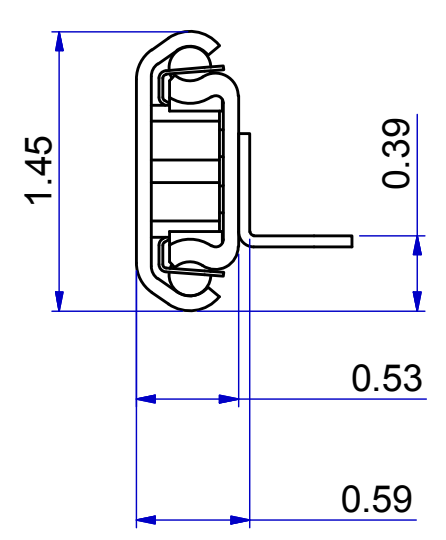
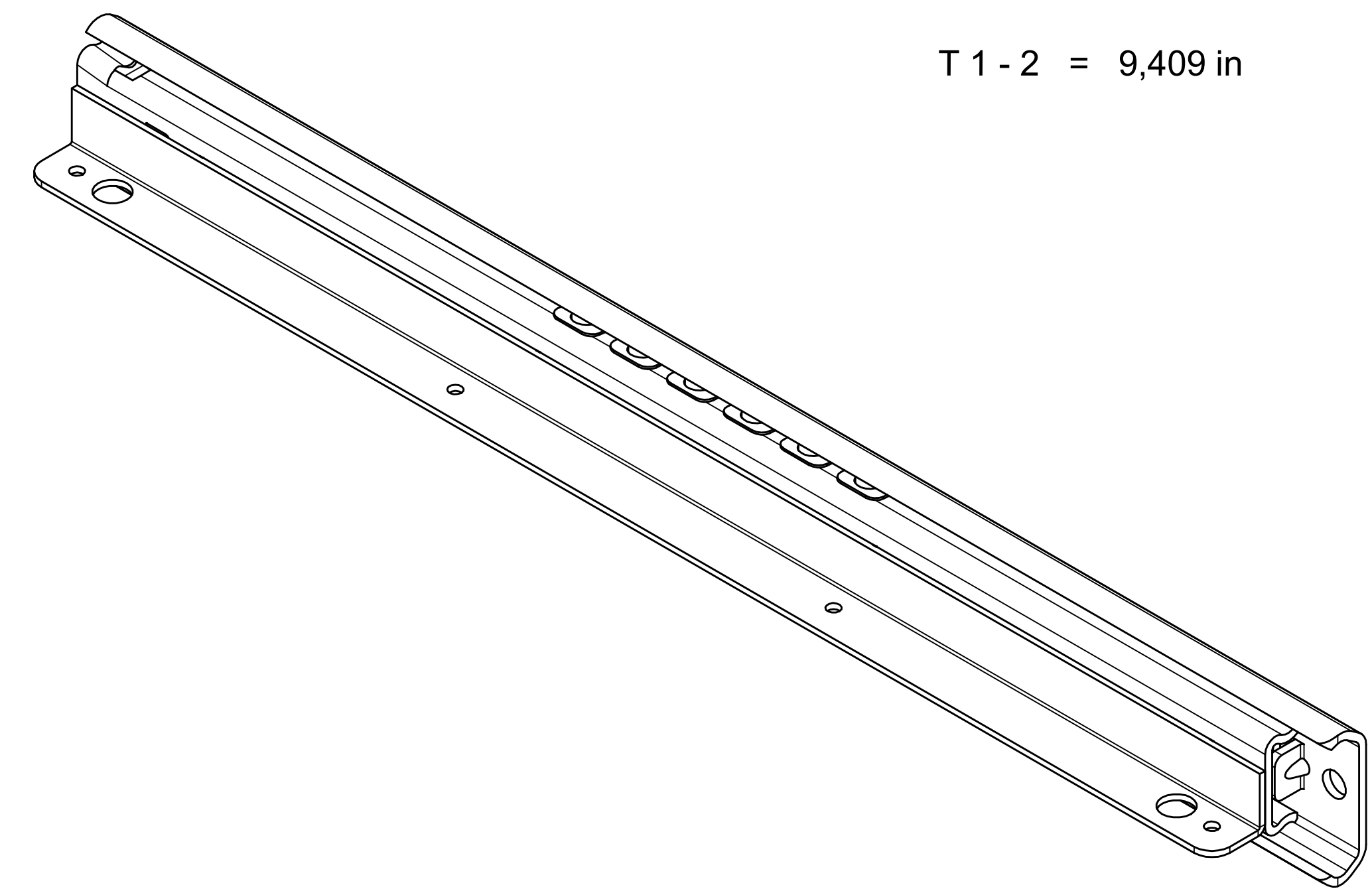
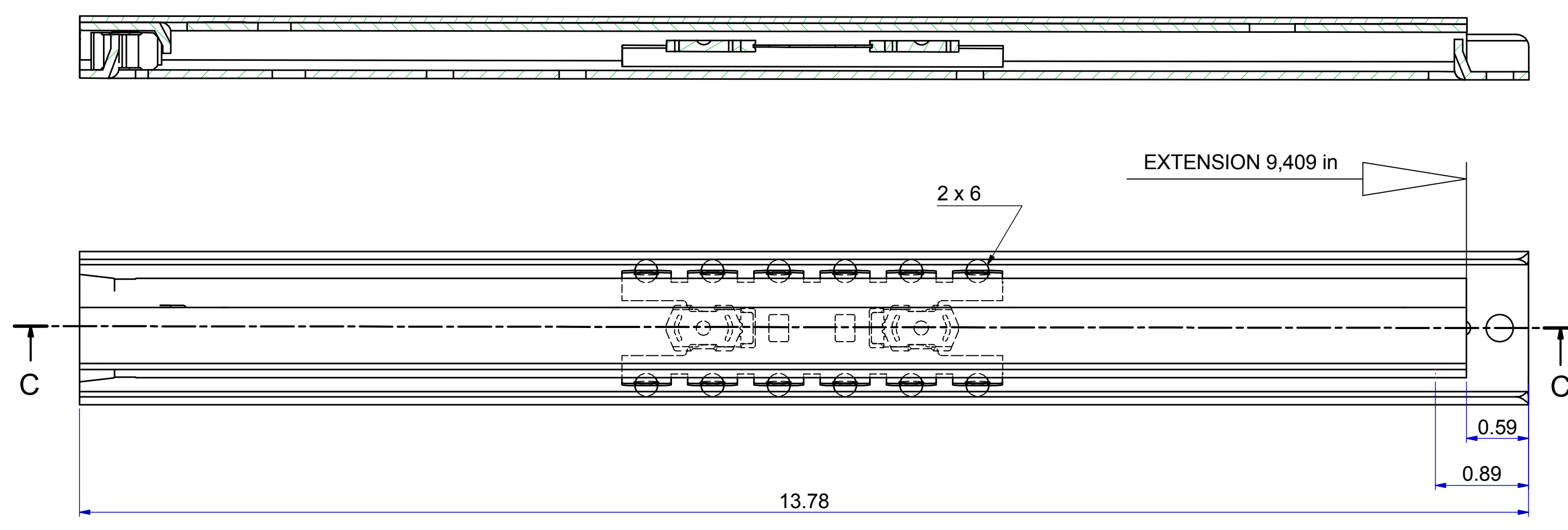
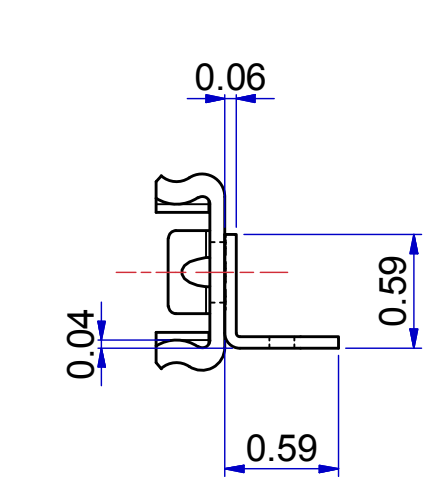
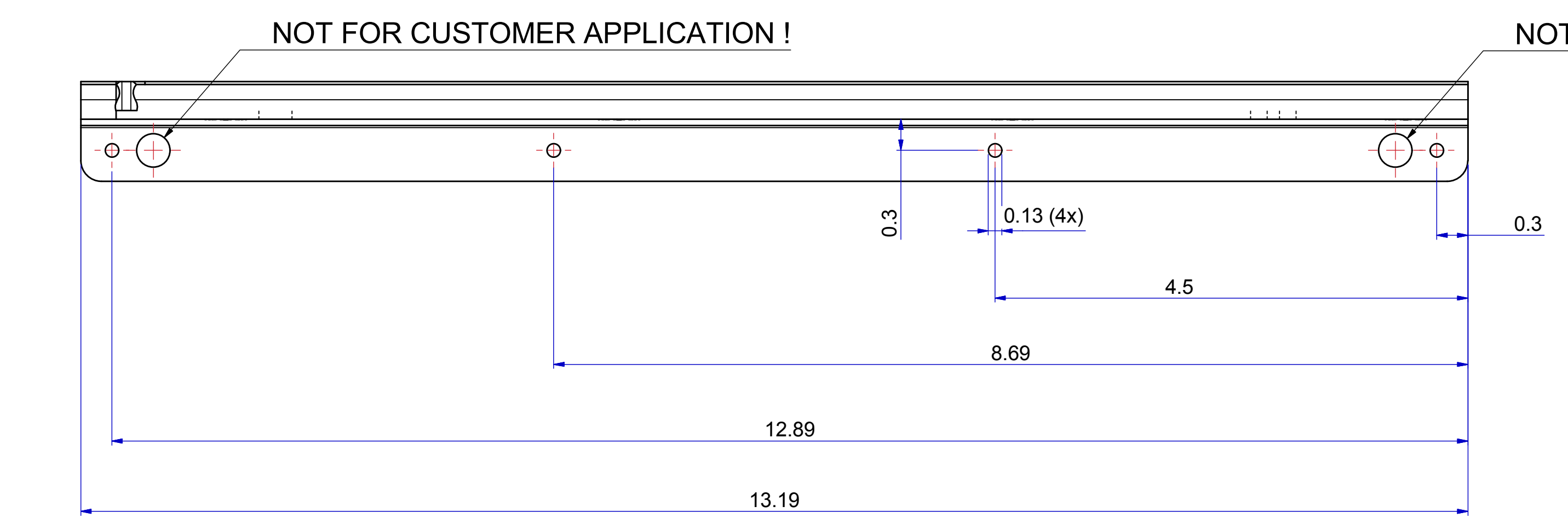

513-07-240-FA2

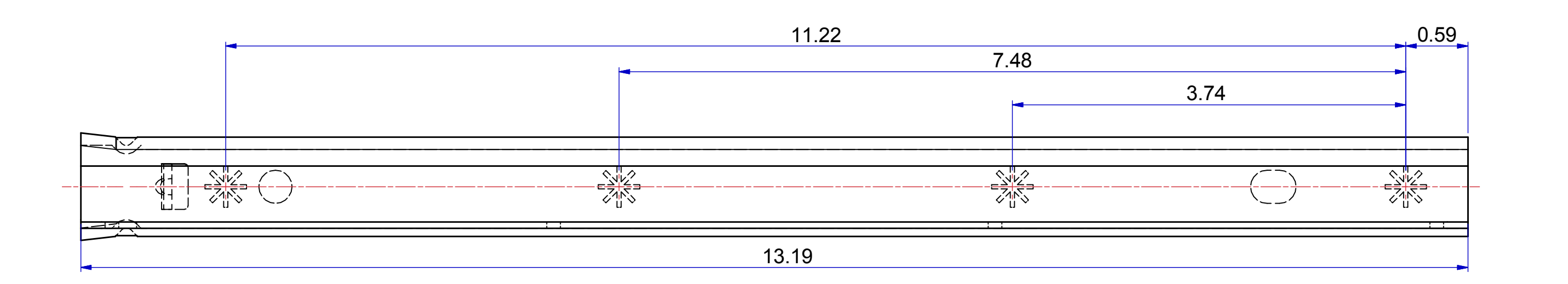

Released for Production

Right hand slide is shown part,
Left hand slide is opposite part.

Dimensions between marks are guide dimensions.

Thomas Regout Int. B.V. reserves the right to alter non-customer specific specifications without notice.

DIMENSIONS ARE CALCULATED FROM METRIC VALUES THOMAS REGOUT B.V. RESERVES THE RIGHT TO ALTER NON-CUSTOMER SPECIFICATIONS WITHOUT NOTICE			
Designer J.Bastings	Gen.Tol.Dim.	Third angle projection	Material
Date 11-8-1994	Gen.Tol.Angle		Treatment
Approver	Gen.Roughness		Draw type Fabrication
Date	Units Inch/deg	Scale 1 : 1	Type Model No. E000032044
Description FINN 350,0 / 239,0 (13,5mm) [13.78"/9.409"(0.531")]			
Format A1	THOMAS REGOUT INTERNATIONAL B.V.		Item No. 107-240_Inch
© THOMAS REGOUT INTERNATIONAL BV, Industrieweg 40, 6219 NR, Maastricht, The Netherlands, +31 (0)43 351 66 66			Revision 00

02	-	-	-
01	-	-	-
00	15-06-2015	GETEKEND IN INVENTOR, LASPUNTEN	W.Jans
Rev	Date	Description	Designer