

T 1-2 = 7,264 in  
T 2-3 = 7,500 in

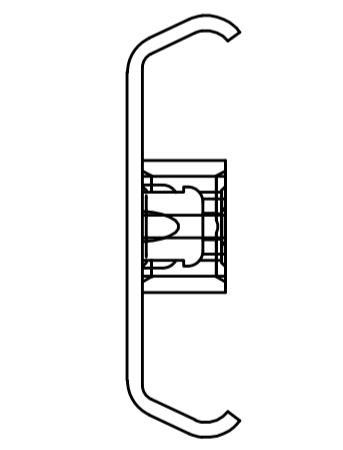

511-12-S02-HDA

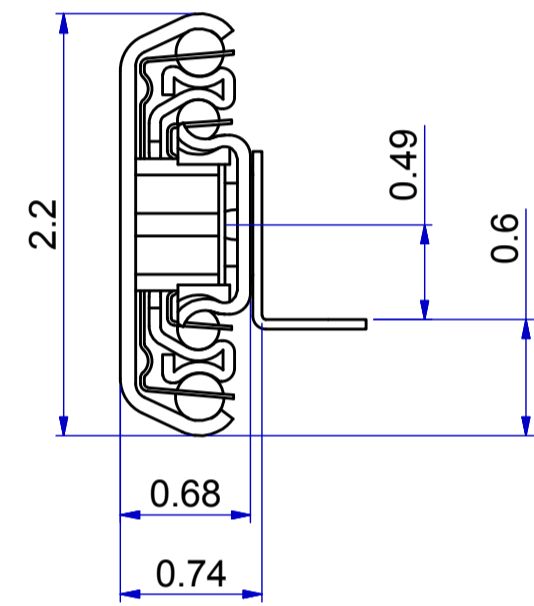
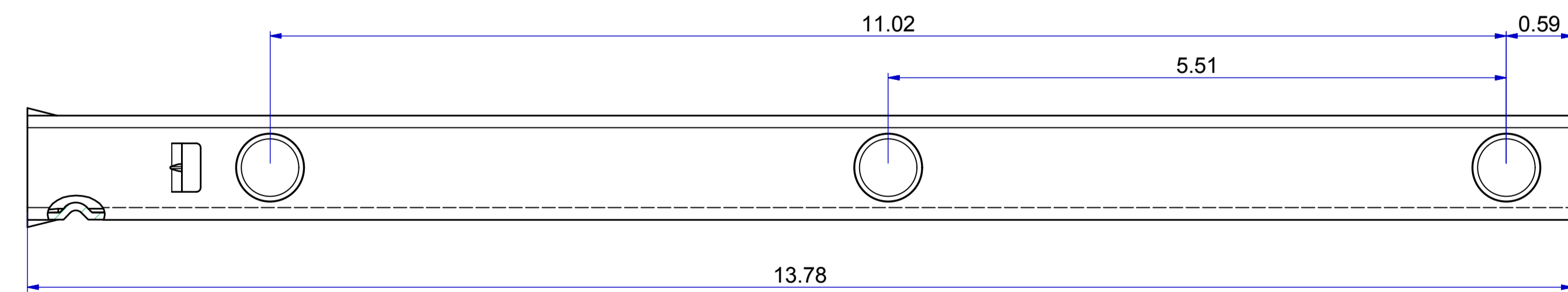
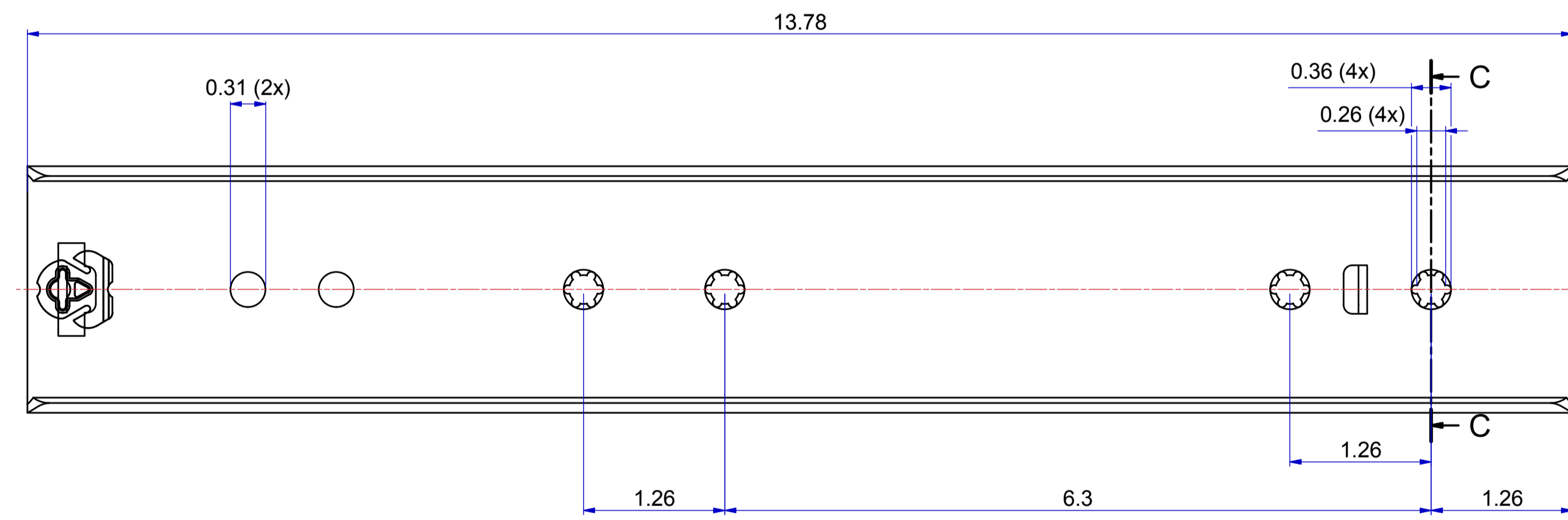
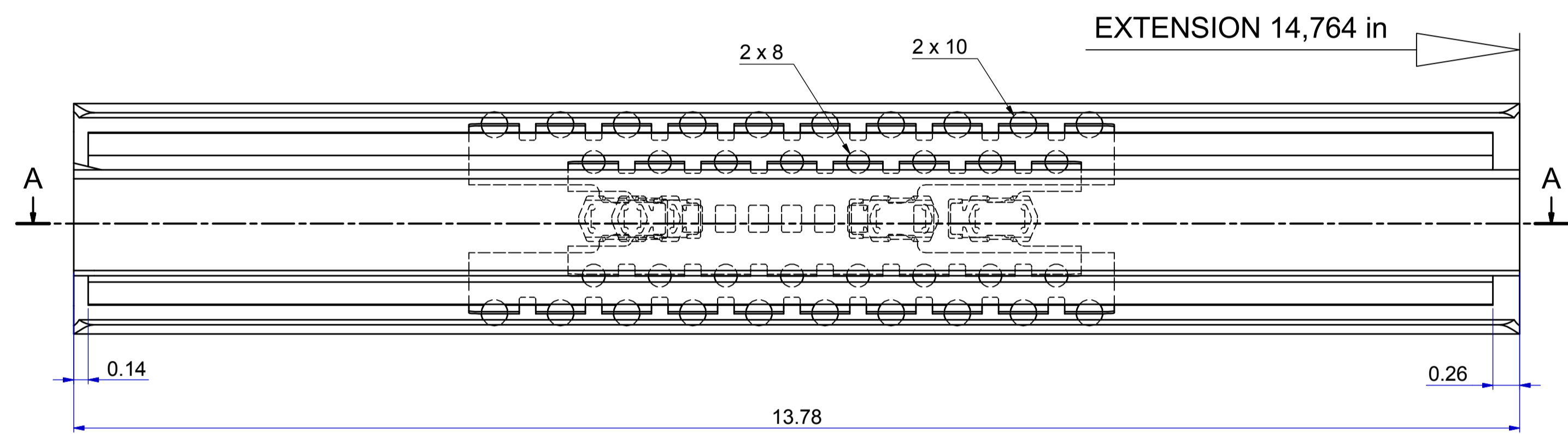
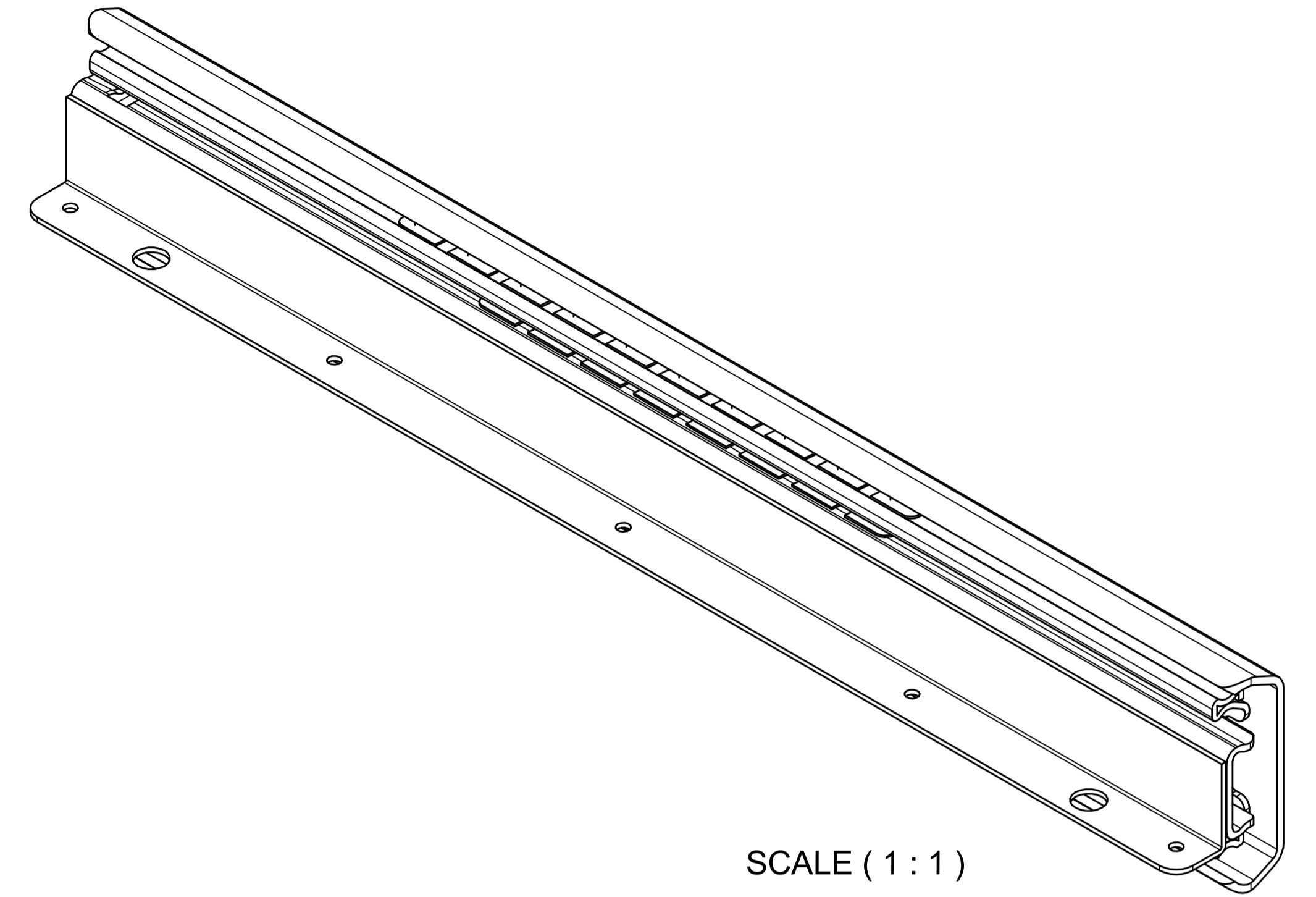
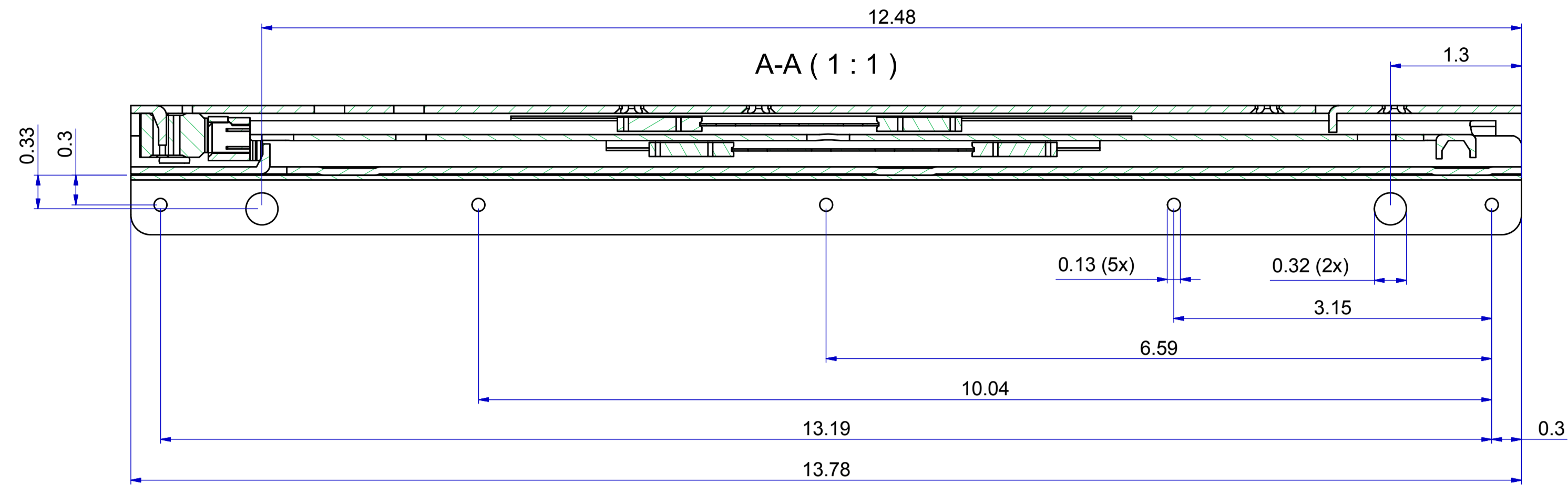
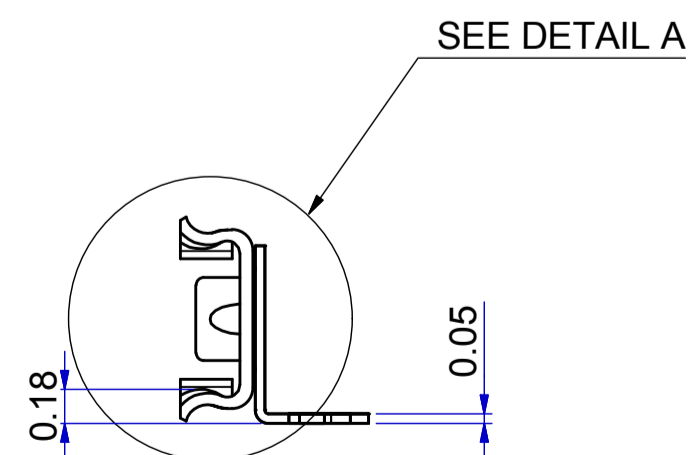

513-12-S02-UB3

FRONT

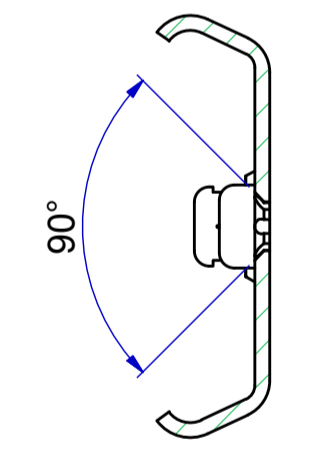

C-C (1:1)

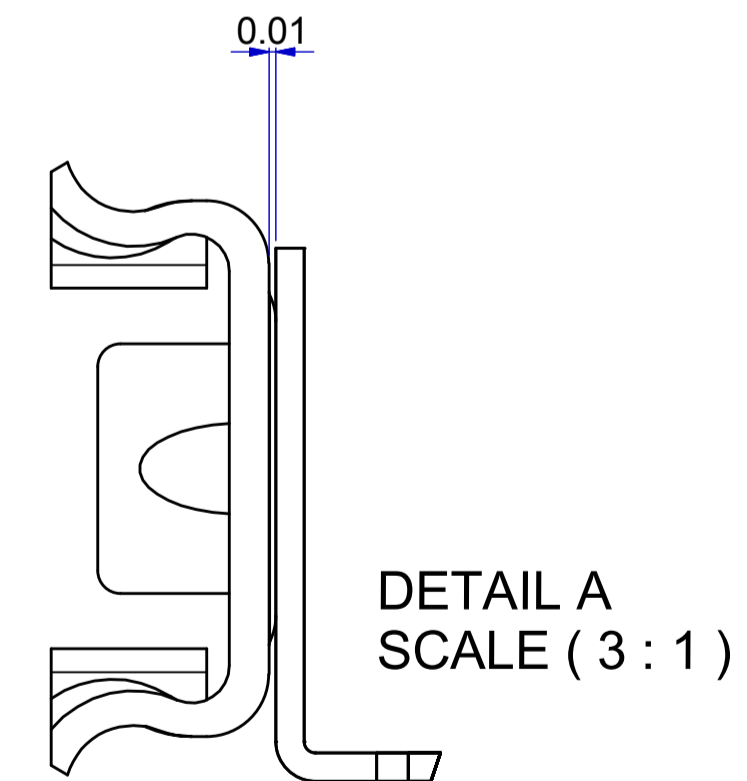

DIMENSIONS ARE CALCULATED FROM METRIC VALUES  
THOMAS REGOUT B.V. RESERVES THE RIGHT TO ALTER NON-CUSTOMER  
SPECIFICATIONS WITHOUT NOTICE

Designer	D.Koper	Gen.Tol.Dim.	Third angle projection	Material	Generic
Date	22-10-2015	Gen.Tol.Angle		Treatment	
Approver		Gen.Roughness		Draw type	Fabrication
Date		Units	Inch/deg	Scale	1 : 1
				Type	Model No. E000036166

Description  
ULF HD 350 / 375 (17,2mm) [13.78"/14.76"(0.677")]  
Released for Production

Format	A1	THOMAS REGOUT INTERNATIONAL B.V.	Item No.	112-S02_Inch	Revision	00
--------	----	-------------------------------------	----------	--------------	----------	----