

T 1 - 2 = 14,685 in

A-A (1:1)

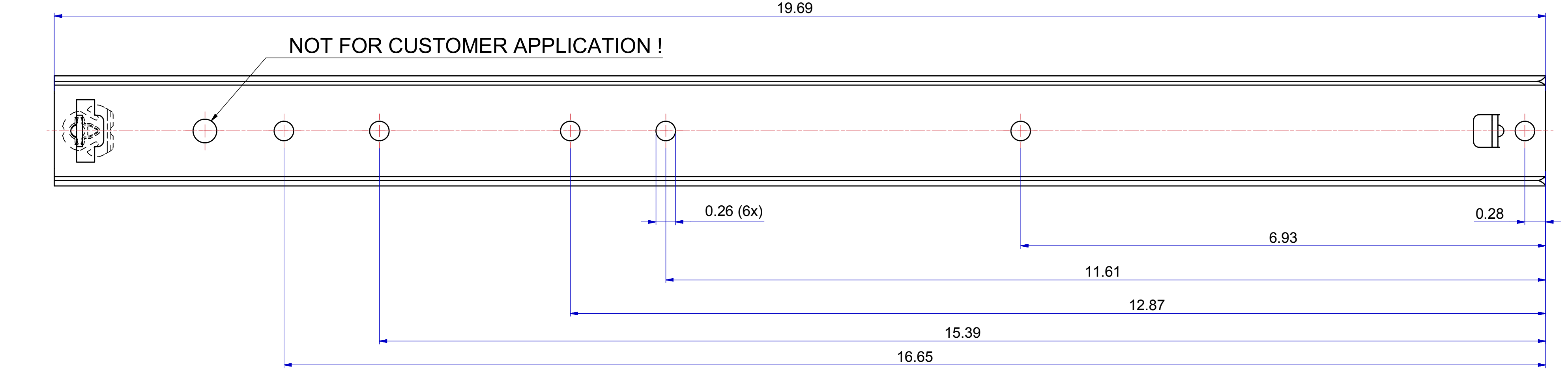
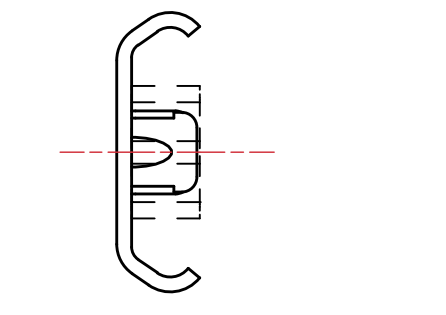
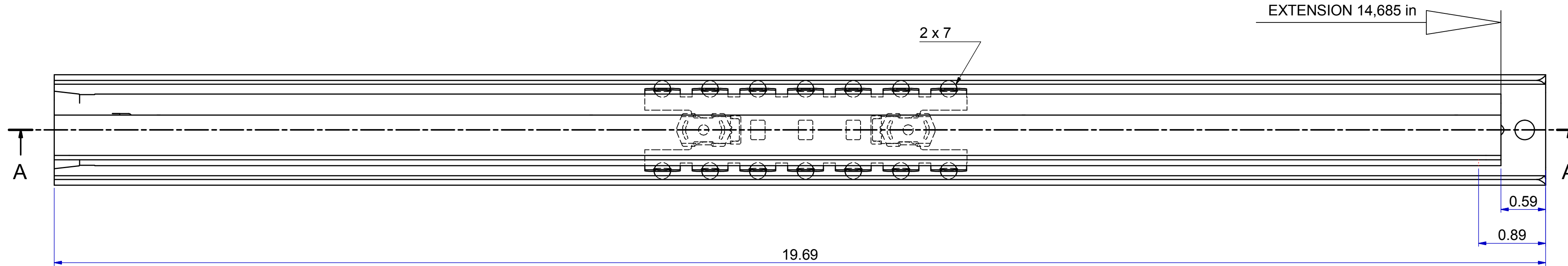
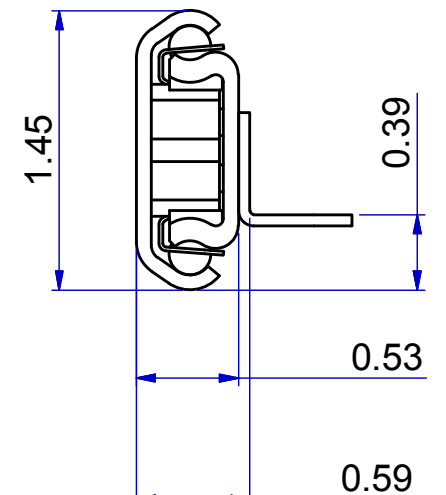
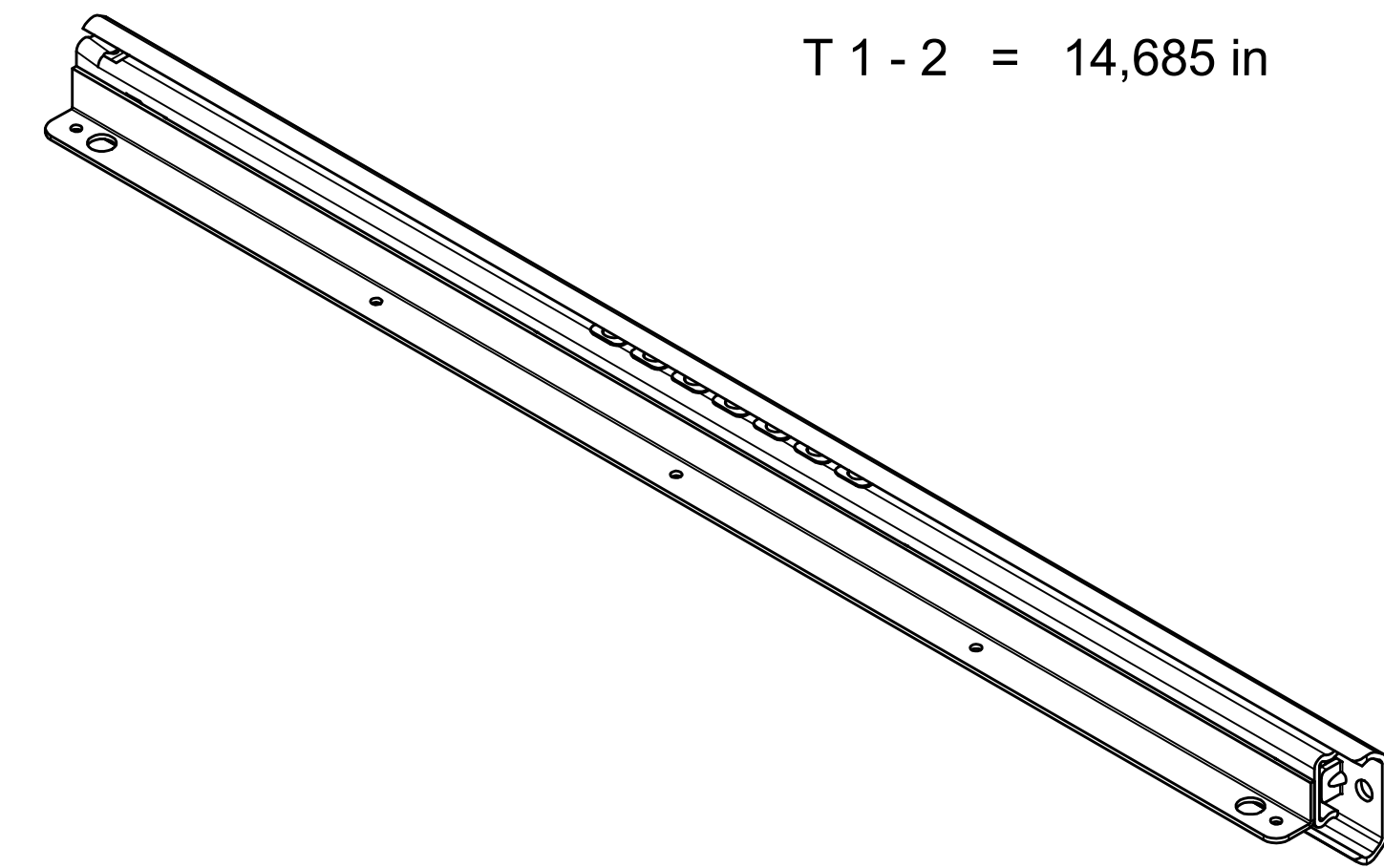
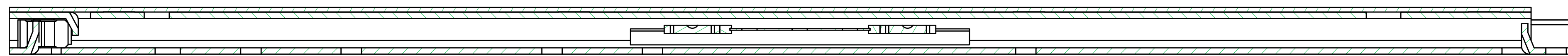

NOT FOR CUSTOMER APPLICATION !

NOT FOR CUSTOMER APPLICATION !

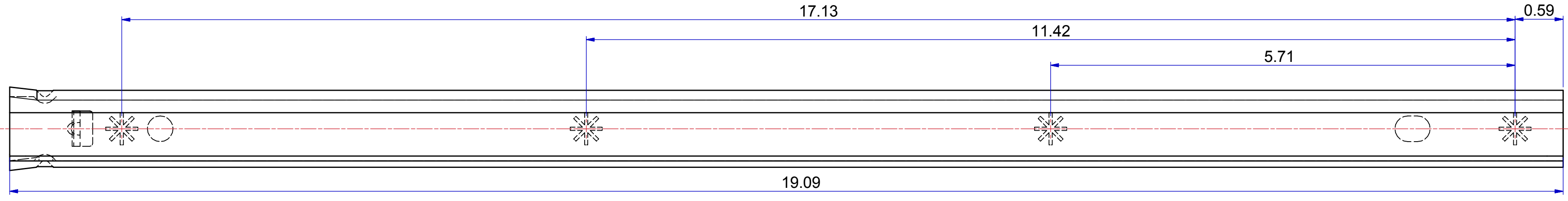
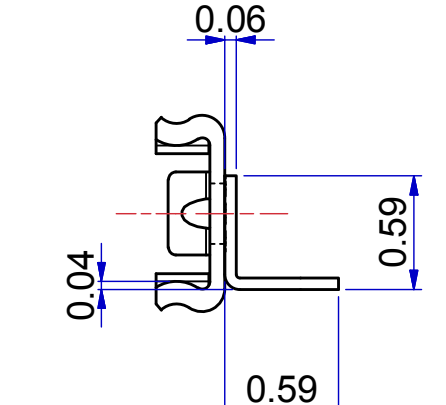
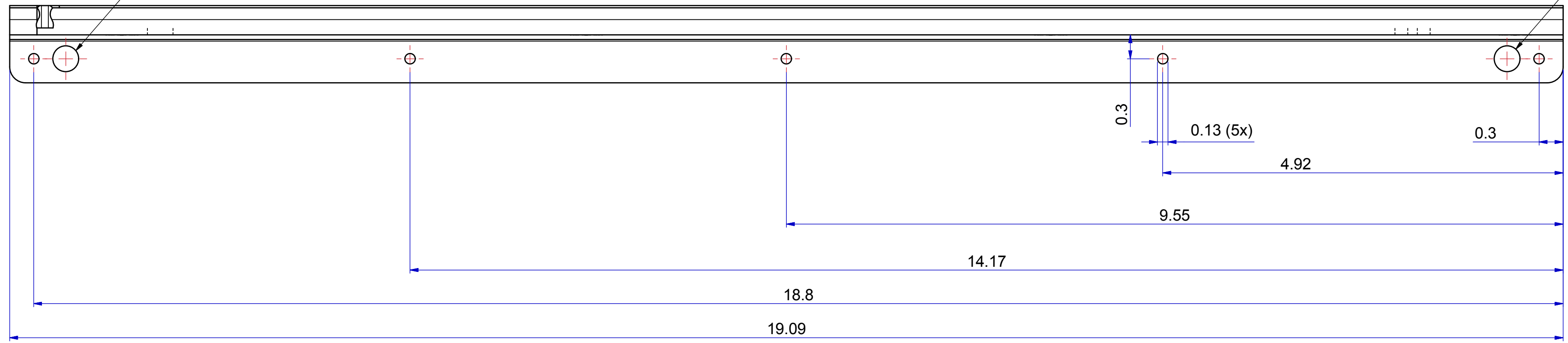

511-07-243-FA1

513-07-243-FA2

Released for Production

Right hand slide is shown part,
Left hand slide is opposite part.

Dimensions between marks are guide dimensions.

Thomas Regout Int. B.V. reserves the right to alter non-customer specific specifications without notice.

DIMENSIONS ARE CALCULATED FROM METRIC VALUES
THOMAS REGOUT B.V. RESERVES THE RIGHT TO ALTER NON-CUSTOMER SPECIFICATIONS WITHOUT NOTICE

Designer	J. Bastings	Gen.Tol.Dim.	Third angle projection	Material	
Date	11-8-1994	Gen.Tol.Angle		Treatment	
Approver		Gen.Roughness		Draw type	Fabrication
Date		Units	Inch/deg	Scale	1 : 1
Description				Model No.	E000031957
FINN 500 / 373 (13,5mm) [19.69"/14.69"(0.531")]				Type	Model No. E000031958
Format	A1	THOMAS REGOUT INTERNATIONAL B.V.		Item No.	107-243_Inch
Revision	00	© THOMAS REGOUT INTERNATIONAL BV, Industrieweg 40, 6219 NR, Maastricht, The Netherlands, +31 (0)43 351 66 66		All rights are reserved.	

02	-	-	-
01	-	-	-
00	15-06-2015	GETEKEND IN INVENTOR, LASPUNTEN	W.Jans
Rev	Date	Description	Designer